

Dual 3-Range Gas Analyzer Systems for Intrinsically Safe Hydrogen Purity & Purge Gas Measurement

Models 4689 502/502
and 4689 505/505



The Company

We are an established world force in the design and manufacture of instrumentation for industrial process control, flow measurement, gas and liquid analysis and environmental applications.

As a part of ABB, a world leader in process automation technology, we offer customers application expertise, service and support worldwide.

We are committed to teamwork, high quality manufacturing, advanced technology and unrivalled service and support.

The quality, accuracy and performance of the Company's products result from over 100 years experience, combined with a continuous program of innovative design and development to incorporate the latest technology.

The UKAS Calibration Laboratory No. 0255 is just one of the ten flow calibration plants operated by the Company and is indicative of our dedication to quality and accuracy.

EN ISO 9001:2000



Cert. No. Q 05907

EN 29001 (ISO 9001)



Lenno, Italy – Cert. No. 9/90A

Stonehouse, U.K.



0255

Use of Instructions



Warning.

An instruction that draws attention to the risk of injury or death.



Note.

Clarification of an instruction or additional information.



Caution.

An instruction that draws attention to the risk of damage to the product, process or surroundings.



Information.

Further reference for more detailed information or technical details.

Although **Warning** hazards are related to personal injury, and **Caution** hazards are associated with equipment or property damage, it must be understood that operation of damaged equipment could, under certain operational conditions, result in degraded process system performance leading to personal injury or death. Therefore, comply fully with all **Warning** and **Caution** notices.

Information in this manual is intended only to assist our customers in the efficient operation of our equipment. Use of this manual for any other purpose is specifically prohibited and its contents are not to be reproduced in full or part without prior approval of the Marketing Communications Department.

Health and Safety

To ensure that our products are safe and without risk to health, the following points must be noted:

1. The relevant sections of these instructions must be read carefully before proceeding.
2. Warning labels on containers and packages must be observed.
3. Installation, operation, maintenance and servicing must only be carried out by suitably trained personnel and in accordance with the information given.
4. Normal safety precautions must be taken to avoid the possibility of an accident occurring when operating in conditions of high pressure and/or temperature.
5. Chemicals must be stored away from heat, protected from temperature extremes and powders kept dry. Normal safe handling procedures must be used.
6. When disposing of chemicals ensure that no two chemicals are mixed.

Safety advice concerning the use of the equipment described in this manual or any relevant hazard data sheets (where applicable) may be obtained from the Company address on the back cover, together with servicing and spares information.

CONTENTS

1	INTRODUCTION	2	8	START-UP	23
			8.1	Instrument Start-Up	23
2	DESCRIPTION	3	8.2	Alarm Set Points	23
2.1	Model 6553 Purge Gas Monitor	3	8.2.1	Type of Alarm Action	23
2.1.1	Range Display	3	8.2.2	Hydrogen alarm Set Point	23
2.2	Model 006540203 or 006548000 Katharometer Analyzer Panel	4	8.3	Electrical Calibration	23
2.3	Model 4234 500/4234 501 Power Supply Units (PSU)	4	8.4	Gas Calibration	23
2.4	Remote Indicator/Controllers	4	8.4.1	Introduction	23
			8.4.2	Gas Range Calibration	23
3	PREPARATION	5	9	OPERATION	24
3.1	Identification	5	9.1	Normal	24
3.1.1	Model 6553 Monitor Unit	5	9.1.1	Purging of Hydrogen Coolant Gas	24
3.1.2	Model 006540 203 or 006548 000 Katharometer Analyzer Panel	5	9.1.2	Filling with Hydrogen Coolant Gas	25
3.1.3	Model 4234 Power Supply Unit	6			
3.1.4	Coding System	7	10	PROGRAMMING	26
4	MECHANICAL INSTALLATION	8	10.1	Range 1 (%H2 in Air)	27
4.1	Locating and Mounting System Items	8	10.1.1	Access to Secure Parameters (Range 1)	27
4.1.1	Model 6553 Gas Monitor	8	10.1.2	Language Page	27
4.1.2	Katharometer Analyzer Panel	9	10.1.3	Set Up Outputs Page	28
4.1.3	Model 4234 Power Supply Unit	10	10.1.4	Electrical Calibration Page	29
4.1.4	Cubicle Mounted System	11			
4.2	Sample Gas Interconnections	12	11	MAINTENANCE	30
5	ELECTRICAL INSTALLATION	13	11.1	General Maintenance	30
5.1	Electrical Interconnections	13	11.1.1	Pressure	30
5.1.1	Model 6553 Gas Monitor	14	11.1.2	Flow	30
5.1.2	Model 006540 203 and 0065480 00 Katharometer Analyzer Panel	17	11.1.3	Leaks	30
5.1.3	Model 4234 Power Supply Unit	18	11.1.4	Vibration	30
5.2	Intrinsically Safe Requirements	19	11.1.5	Contamination	30
5.2.1	Cable Requirements	19	11.1.6	Ambient Temperature	30
5.2.2	Recommended Cables	19	11.1.7	Bridge Current	30
5.2.3	Installing Remote Ancillary Items	19	11.2	Diagnostic Tests	30
5.2.4	Full Intrinsically Safe Requirements	19	11.2.1	Checking Output of the PSU	30
			11.2.2	Checking Integrity of Zener Diode Safety Barrier Devices	30
6	SETTING UP	20	11.2.3	Checking the Katharometer Output	30
6.1	Katharometer Analyzer Panel – Filling the Drying Chamber	20	11.3	Routine Maintenance	30
6.2	Setting Sample Flow	20	11.3.1	Hydrogen Katharometer Calibration	30
6.3	Electrical Checks	21	11.3.2	Purge Gas Katharometer Calibration	31
6.3.1	Power Supply Unit Output	21	11.3.3	Changing Desiccant in Drying Chamber	31
6.3.2	Zener Diode Safety Barrier Devices	21	11.4	Repair Maintenance	31
6.3.3	Checking System Earth	21	11.4.1	Removing Liquid from Katharometer Measurement Block	31
7	CONTROLS & DISPLAYS	22	11.4.2	Removal/Replacement of an Indicator Unit	32
7.1	Displays	22	11.4.3	Error Messages	32
7.2	Switch Familiarization	22	12	SPARE PARTS LIST	32
			12.1	Consumables	32
			12.2	Routine Maintenance Parts	32
			12.3	Repair Maintenance Parts	32
			13	SPECIFICATION	33

1 INTRODUCTION



Note. Argon may be used as an alternative purge gas to the CO₂ referred to in this manual.



Warning. This operating manual applies only to those systems which have been designed and constructed to the standards specified in the schedules of the ATEX certificates listed. The separate units to which these certificates apply are clearly identifiable by model numbers and the data on the identification and ATEX certification labels fixed to them. Other combinations of similar equipment built to any earlier specifications are not covered by BASEFA certificate number BAS Ex 01E2044. This is particularly important where new replacement units are to be incorporated into existing installations covered by any earlier certification standards. If in any doubt about the installation of particular combinations of certified equipment, please contact the Company for advice before proceeding.

It is essential that units are installed strictly in accordance with the appropriate standards for electrical equipment for use in flammable atmospheres. Any deviation from the specified installation conditions, or any unauthorized repairs or adjustments can invalidate the safety assurances given by the certification of the unit.

The different units of the system are:

- 1) The Model 6553 Gas Monitor Unit which is available in several options. The inputs to these units are certified to code [EEx ia] IIC Tamb= -20 to 40°C under BAS 01 ATEX 7043 certificate with the unit installed in the **safe** area only.
- 2) The Model 006539-960K (or J) and 006548-001 Katharometer Units which forms part of an intrinsically safe Model 006540-203 and 006548-000 Katharometer Analyzer Panel. The 006539-960 and 006548-001 units are certified to code EEx ia IIC T4 Tamb= -20 to 55°C under BAS 01 ATEX 1042 certificate for installation in the **hazardous** area (ZONE 0).
- 3) The Model 4234 500/501 constant current Power Supply Unit, which provides a suitable supply for one katharometer unit. These units have their output certified to code [EEx ia] IIC Tamb= -20 to 55°C under BAS 01 ATEX 7041 certificate for installation in the **safe** area only.

If further information or assistance is required, Company specialist staff, service centres or worldwide organization may be contacted through the most convenient address given on the back cover of this manual. Specialist training courses can also be arranged by our Training Centre.

The ultimate responsibility for any particular installation lies with the installing user/contractor.

This manual gives the installation, operating and maintenance information for the Company's range of Model 6553 Intrinsically Safe Gas Analyzer Systems, normally used with hydrogen cooled electrical power generators.

The complete 6553 Analyzer system uses a combination of three different units. Each unit is independently certified for use as part of an intrinsically safe system to meet the standards of the ATEX directive 9/94/EC for use in association with Group IIC (hydrogen) hazardous atmospheres in accordance with the following standards:

EN 50014 : 1997 + Amendments 1 & 2 EN 50020 : 1994	} 006539 & 006548 Katharometer Units 4234 500/501 Power Supply Unit 6553 Gas Monitor Unit
EN 50284 : 1999	006539 & 006548 Katharometer Units
EN 50039 : 1980	System

2 DESCRIPTION

All the various system options consist of one or more of the following units with the further option of fitting the monitor and power supply units in a cubicle.

2.1 Model 6553 Purge Gas Monitor

The Purge Gas Monitor Unit is suitable for panel mounting or in a control cubicle in the **safe** area. This monitor uses two digital displays with protected access for zero adjustments and has range selector switches – see Fig. 2.1.

In most applications this instrument has 100% redundancy. However, it can be used for monitoring two katharometer units on separate generators.

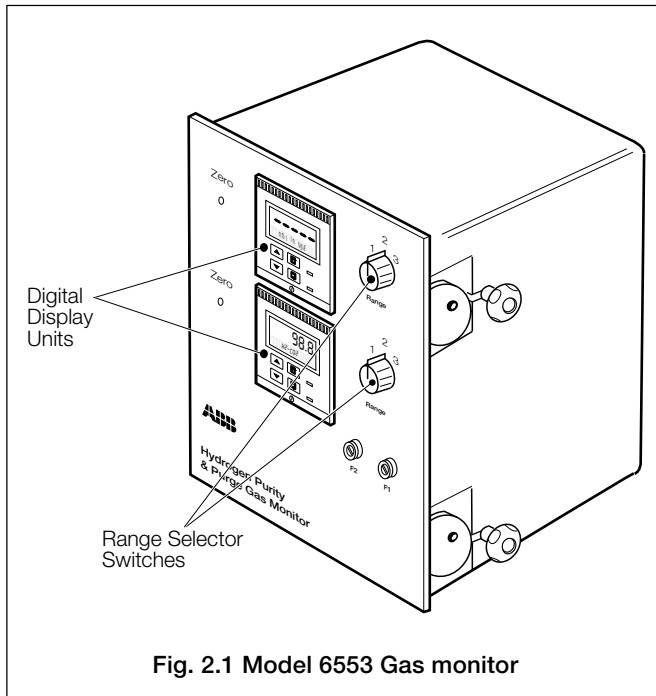

Fig. 2.1 Model 6553 Gas monitor

2.1.1 Range Display

A selector switch for each display provides independent parameter selection as follows:

- Position (1) Percentage of Hydrogen in Air by volume.
This is the hydrogen purity measurement of the coolant gas under normal operation of the system. The display covers a range of 85 to 100% or 80 to 100% hydrogen in air depending on the range selected. Alarm output and a value retransmission signal (4 to 20mA) are provided for this switch position only.
- Position (2) Percentage of Hydrogen in Carbon Dioxide by volume.
This range is for use in hydrogen filling or purging operation. Alarm and retransmission signal are inhibited in this switch position.
- Position (3) Percentage of Air in Carbon Dioxide by volume.
This range is for use in carbon dioxide filling or purging operation. Alarm and retransmission signal are inhibited in this switch position.

A further option of providing remote indication of range selector switch may be available dependent on the number of alarms specified.

The Model 4689 displays are dedicated variants of the Company's Model 4600 Series Indicator/Controllers. With this particular variant (4689), the displays and alarm indicators on the front panel remain the same but software control is specific to the katharometer systems. The relay action of the alarms is fixed as 'fail safe'. All user programmable data can be protected from unauthorized alteration by a programmable 5-digit security number.

The zero adjustments on the front panel of the monitor allow remote zeroing of the katharometers which are mounted in the **hazardous** area. The adjustment access for a particular display is adjacent to the display and at the same level.

The monitor unit has a protective case which can be removed for access to the interior without removing the whole monitor unit from the control panel.

The monitor also contains encapsulated zener diode safety barrier devices to limit the electrical energy level that can be applied from the instrument circuits into the **hazardous** area. These devices are located below the display units, on a rail which **MUST** be earthed (grounded). A metal screening arrangement segregates the connections made to equipment in the **hazardous** area. The unit is protected on the mains input side by two fuses, one for each circuit, which are accessible from the front of the panel.

...2 DESCRIPTION

2.2 Model 006540203 or 006548000 Katharometer Analyzer Panel – Fig. 2.2

Each panel comprises a metering valve, a drying chamber, a thermally lagged katharometer (006539 type or 006548 type) and a flowmeter. These items are mounted on a flat panel suitable for fixing to a vertical surface close to the sample point. The katharometers are calibrated for the hydrogen purity measurement as well as hydrogen in carbon dioxide and air in carbon dioxide.

Each katharometer assembly incorporates a Wheatstone Bridge made up of fine glass coated platinum filaments. One pair of parallel arms is sealed in the reference gas and the other pair exposed to the sample gas.

When the intrinsically safe stabilized current from the 4234 power supply unit (model 4234 500 or 4234 501) is passed through this bridge, the temperature of the platinum filaments rises to a point of thermal equilibrium. Under conditions which are arranged to give minimum radiation and convection heat transfer, the equilibrium temperature depends on the thermal conductivity of the gas surrounding the filament. Thus any difference between the thermal conductivity of reference and sample gases causes an imbalance in the bridge; this imbalance (as a millivolt signal) is indicated by the monitor unit.

Zener diodes are connected across the input connections from the power supply unit to the katharometer in order to limit the maximum voltage which could be developed across the filament bridge under external fault conditions. Under fault conditions the current is limited to a safe value by the power supply unit.

2.3 Model 4234 500/4234 501 Power Supply Units (PSU) – Fig. 3.3



Note. Do not connect mains supply to the PSU with the output terminals on open circuit.



Caution. Ensure that the PSU is correct for the mains supply voltage available. A nominal 115 V unit cannot be adapted for use with a nominal 230 V supply, or the other way around.

To operate a katharometer unit in the hazardous area, one Model 4234 PSU is required for each katharometer. The PSU supplies a stabilized mA DC signal, and must be mounted in the safe area. There are two separate versions available:

- Model 4234 500 for a nominal 230 V AC supply voltage
- Model 4234 501 for a nominal 115 V AC supply voltage

The stabilized current output is current and voltage limited to restrict the energy supply into the hazardous area.

The PSU is housed in a metal case fitted with lugs for wall/panel mounting. Cable gland entries are provided at opposite ends of the case for supply voltage input and stabilized output cables to the hazardous area.

The circuit is protected by cartridge fuses. These fuses must have a high breaking capacity (HBC) rating of 1500A to comply with the terms of the certification.

2.4 Remote Indicator/Controllers

The 6553 monitor unit has provision for retransmission values and ancillary indicator/controllers may be connected to these outputs, providing that they are installed in the **safe** area and the installation conforms to the requirements given in Section 5.1.

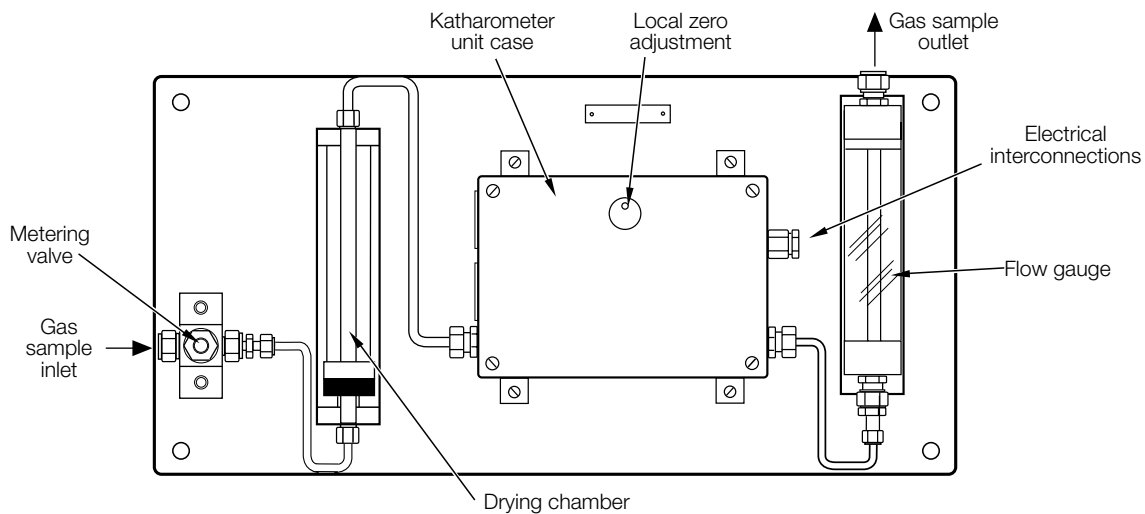

Fig. 2.2 Location of Items – Model 6540 203 and 6548 000 Katharometer Analyzer Panels

3 PREPARATION

3.1 Identification

It is essential that installers and users clearly identify the various units of the monitoring system as follows:

3.1.1 Model 6553 Monitor Unit – Fig. 3.1

The 6553 monitor is available in several options, these being defined by the code number as given in Section 3.1.4.

The identification and certification labels are fixed to the outside of the monitor case as shown in Fig. 3.1. The precise interpretation of the identification code gives information on the 6553 system as shown in Section 3.1.5.

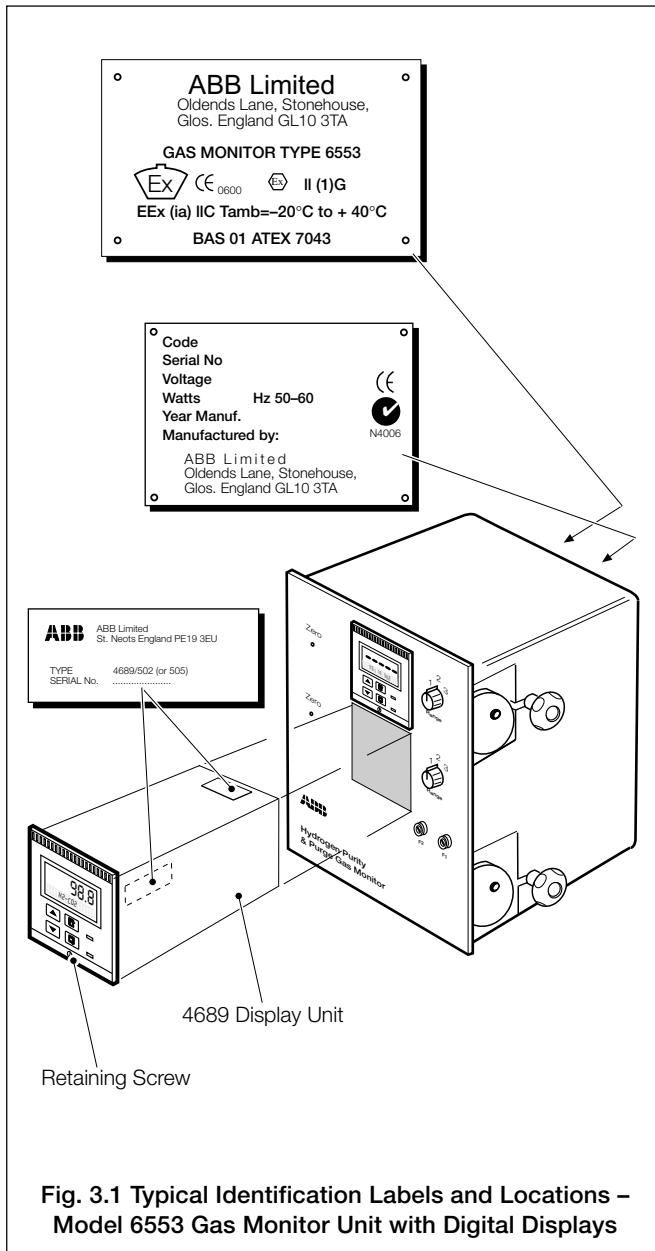

Note. The precise identity of the display unit is given on the identification label shown in Fig. 3.1.

3.1.2 Model 006540 203 or 006548 000 Katharometer Analyzer Panel – Fig. 3.2

The identification of a panel is given by the panel reference number label as shown in Fig. 3.2. The identification and certification labels of the individual katharometer units (fixed to the katharometer case) are also shown in Fig. 3.2.

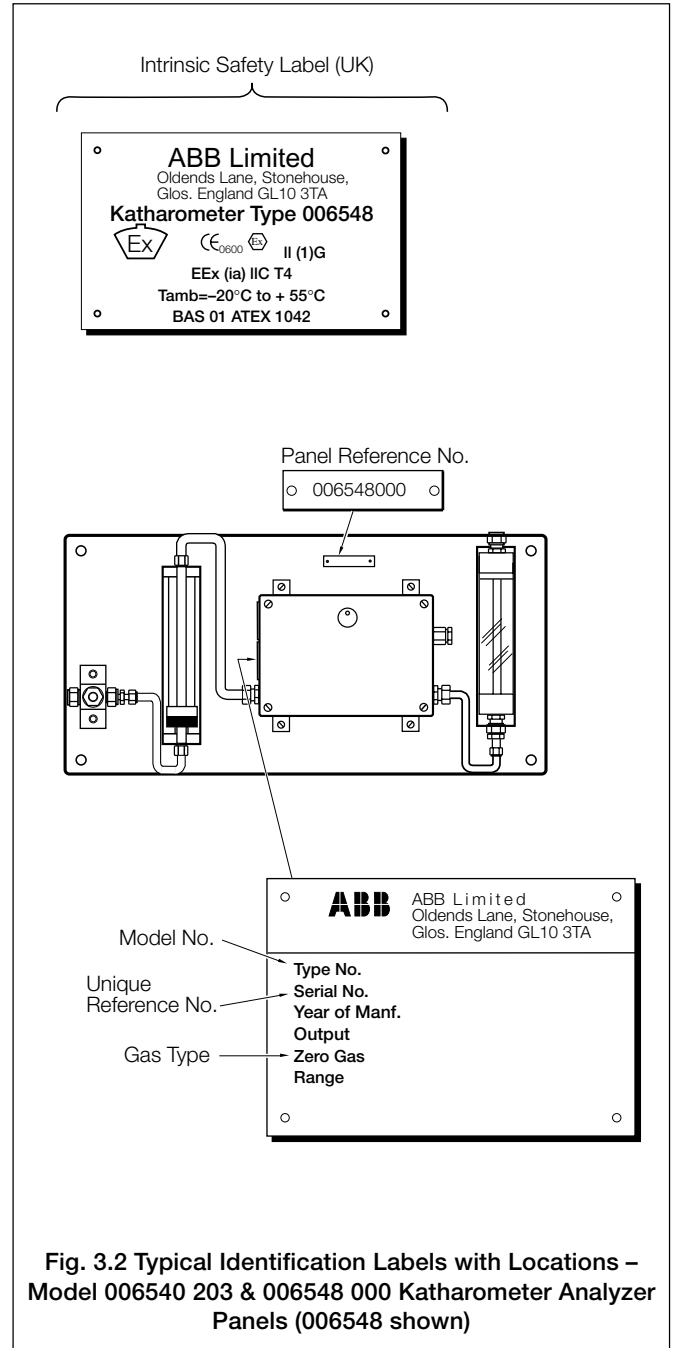

3.1.3 Model 4234 Power Supply Unit – Fig. 3.3

The identification and certification labels are fixed to the outside of the unit case, as shown.

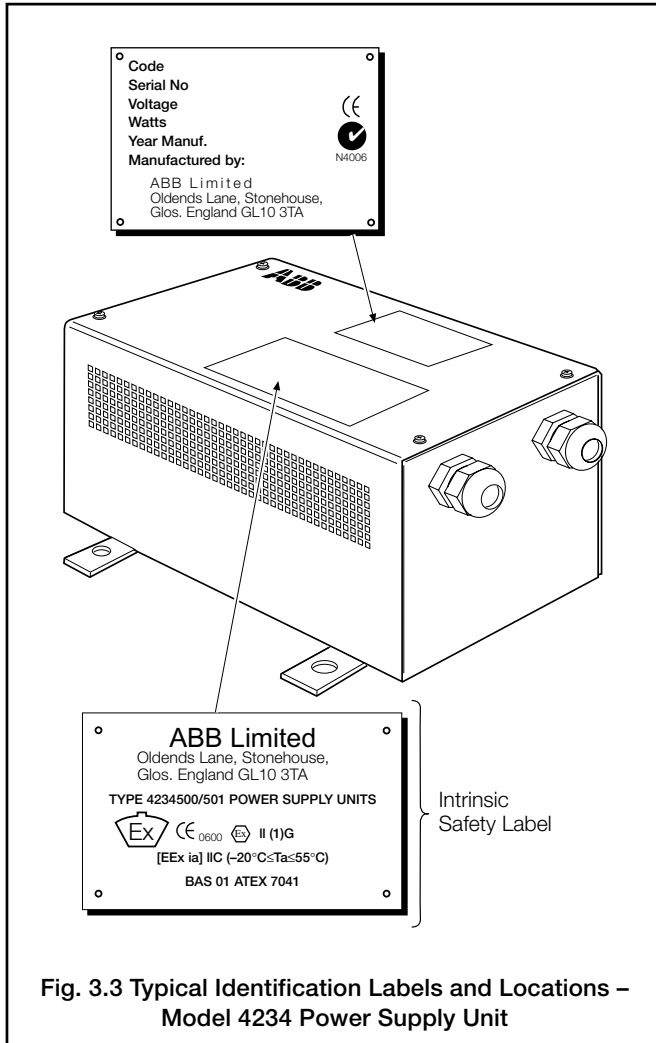

Fig. 3.3 Typical Identification Labels and Locations – Model 4234 Power Supply Unit

3.1.4 Coding System

6553/	X	X	X	X	X	X	X	X	X	X	X
	A	B	C	D	E	F	G	H	J	K	
Features of Upper Display											
Scale of Upper Display											
Features of Lower Display											
Scale of Lower Display											
Range Selector Switch											
Not Used											
Fitted with Labels											
Cubicle Type											
Special Features											
Mains Supply											

The equipment conforms with the requirements of ATEX directive for class IIC gases to Code EEx ia IIC provided that the equipment is installed in accordance with instructions provided. The display unit and power supply units **must be** installed in a **safe** (non-hazardous) area, and katharometer panel may be mounted close to the sample point in the **hazardous** area.

Ordering Code – 6553 Hydrogen Purity and Purge Gas

A Features of Upper Display

6 Two alarms + retransmission (4 to 20mA)

B Scale of Upper Display

- 1 100 to 85% H₂ in Air
- 2 100 to 80% H₂ in Air
- 3 0 to 100% Air in CO₂, 0 to 100% H₂ in CO₂, 85 to 100% H₂ in Air
- 4 0 to 100% Air in CO₂, 0 to 100% H₂ in CO₂, 80 to 100% H₂ in Air
- 5 85 to 100% H₂ in Air
- 6 80 to 100% H₂ in Air
- 7 0 to 100% Air in Ar, 0 to 100% H₂ in Ar, 85 to 100% H₂ in Air
- 8 0 to 100% Air in Ar, 0 to 100% H₂ in Ar, 80 to 100% H₂ in Air

C Features of Lower Display

- 0 Indicator Not Fitted
- 3 Two alarms + retransmission (4 to 20mA)

D Scale of Lower Display

- 0 Indicator Not Fitted
- 1 0 to 100% Air in CO₂, 0 to 100% H₂ in CO₂
- 2 100 to 85% H₂ in Air
- 3 100 to 80% H₂ in Air
- 4 0 to 100% Air in CO₂, 0 to 100% H₂ in CO₂, 85 to 100% H₂ in Air
- 5 0 to 100% Air in CO₂, 0 to 100% H₂ in CO₂, 80 to 100% H₂ in Air
- 6 85 to 100% H₂ in Air
- 7 80 to 100% H₂ in Air
- A 0 to 100% Air in Ar, 0 to 100% H₂ in Ar, 85 to 100% H₂ in Air
- B 0 to 100% Air in Ar, 0 to 100% H₂ in Ar, 80 to 100% H₂ in Air

E Range Selector Switch

- 0 Not fitted
- 2 Fitted, with facilities for Remote Indication of Switch Position – only upper display fitted
- 3 Fitted with two range switches, upper and lower display + remote indication of selected ranges

F Additional Output Signal – Not Used**G Language**

- 1 English
- 2 French
- 3 German
- 4 Polish

H Type of Cubicle

- 1 Without Cubicle.
- 2 Cubicle – 2 x 3-range only (Ar or CO₂)
- 4 Cubicle – dual display
- 5 Cubicle – single display

J Special Features

- 0 None
- 9 Fitted

K Mains Supply

- 1 115V, 50/60Hz
- 2 230V, 50/60Hz

Valid Option Combinations (6553/[X])

[X]	2 x 3 ranges	Purity only: Single Display (upper)	3-Range: Single Display (upper)	Std. purge system
A	6	6	6	6
B	3,4,7,8	1,2,5,6	3,4	1,2,5,6
C	3	0	0	3
D	4,5,A,B	0	0	1
E	3	0	2	2
F	0	0	0	0
G	1 to 3	1 to 3	1 to 3	1 to 3
H	1,2	1,5	1,5	1,4
J	0,9	0,9	0,9	0,9
K	1,2	1,2	1,2	1,2

4 MECHANICAL INSTALLATION

4.1 Locating and Mounting System Items

4.1.1 Model 6553 Gas Monitor – Fig. 4.1



Caution. The monitor must be located in the safe area of the application plant in a sheltered interior environment.

The monitor is intended to be panel mounted in a position to suit reading of the displays and with access to the rear to enable wiring interconnections to be made. The panel preparation requirements and installation dimensions are shown in Fig. 4.1. The monitor is secured to the panel by four adjustable cam brackets – two each side of the monitor chassis.

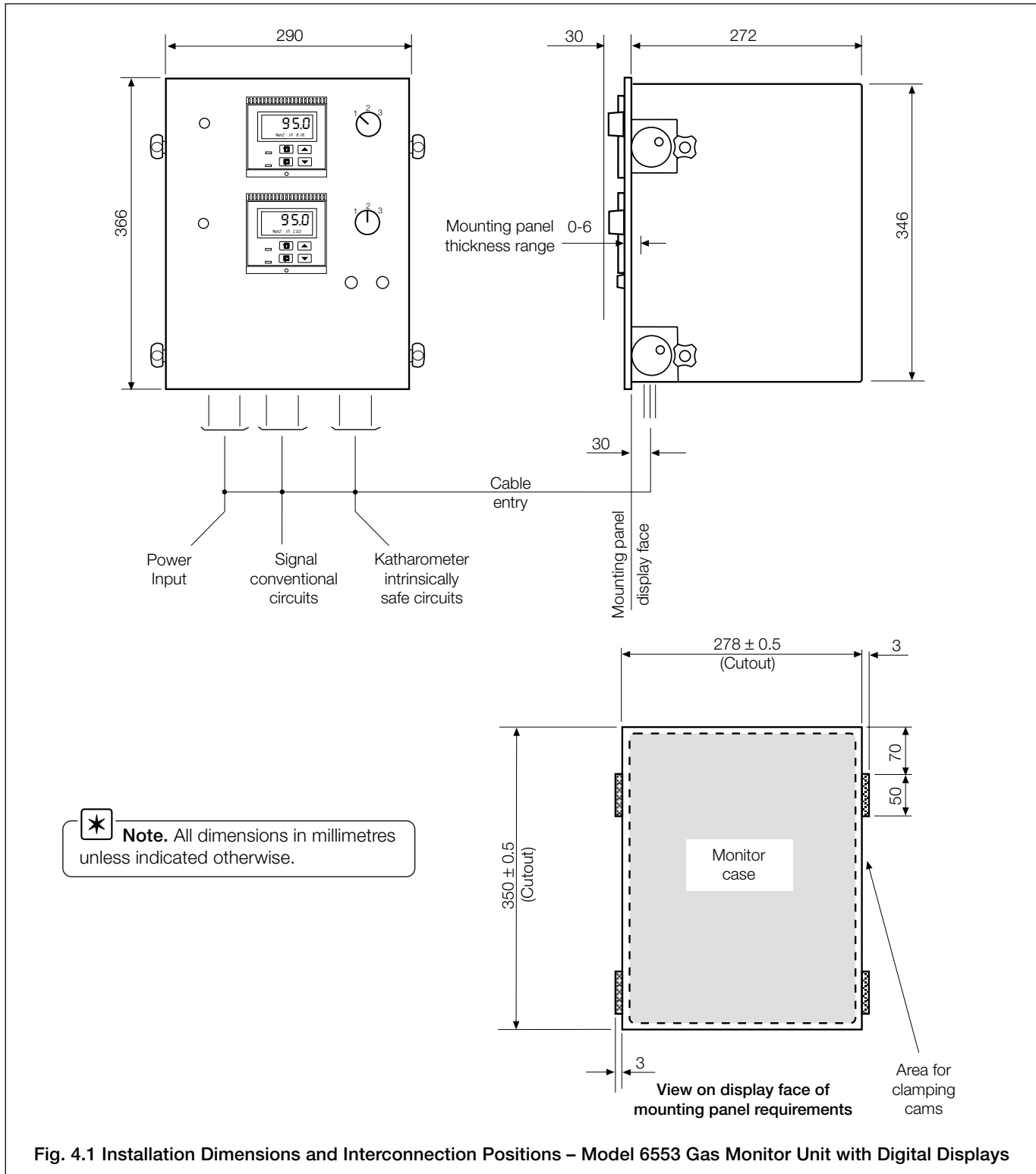

Fig. 4.1 Installation Dimensions and Interconnection Positions – Model 6553 Gas Monitor Unit with Digital Displays

4.1.2 Katharometer Analyzer Panel – Fig. 4.2



Caution. The panel is located in the hazardous area (zone 0,1 or 2) of the application plant in a sheltered interior environment.

Avoid a location which subjects the katharometer unit to direct sunlight. When two katharometer panels are used they should be positioned so as to be at the same ambient temperature.

The katharometer unit is fixed to the panel which has fixing holes at each corner and should be mounted on a suitable vertical surface close to the sample tapping point. The installation dimensions for the panel is shown in Fig. 4.2.

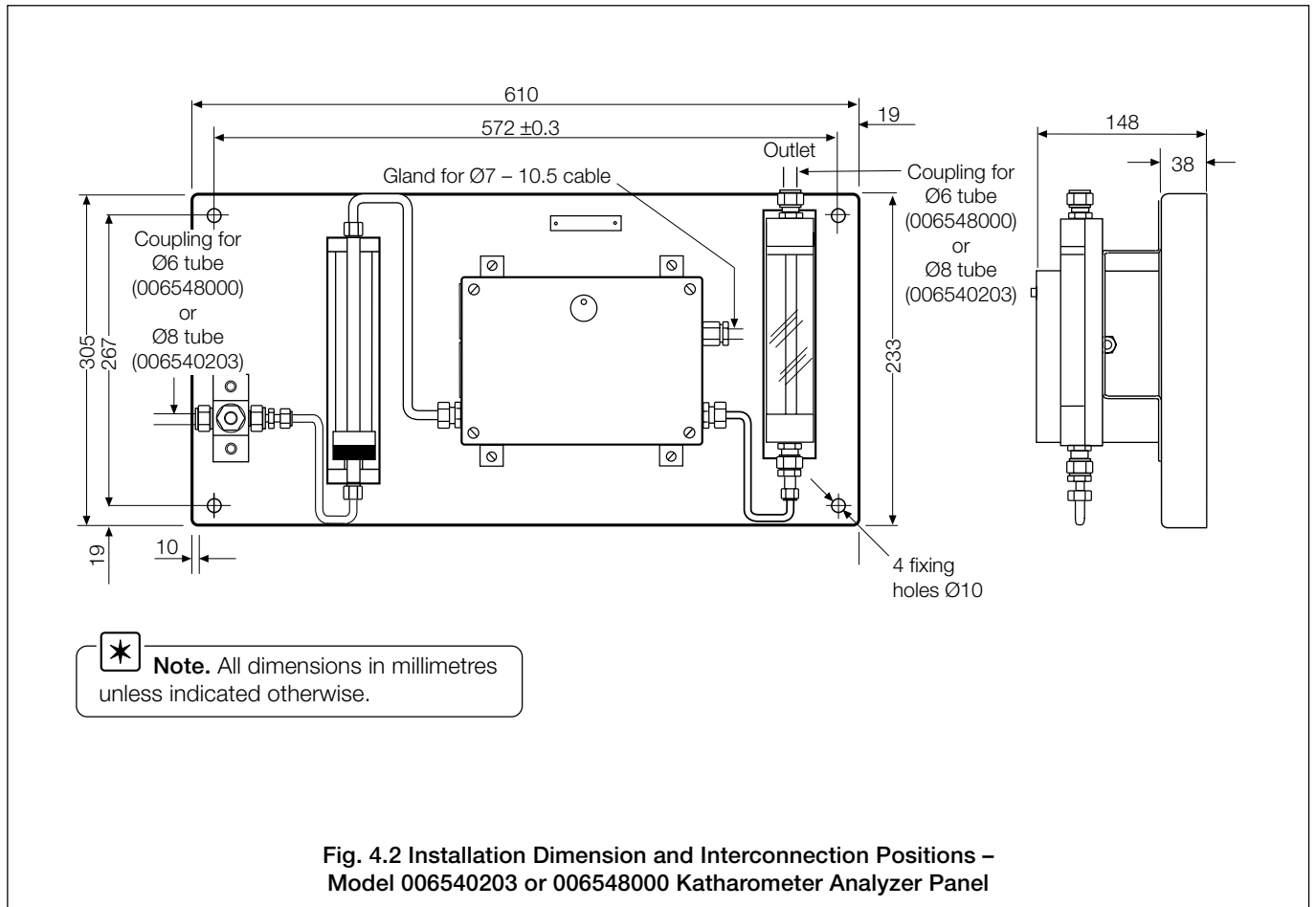

...4 MECHANICAL INSTALLATION

4.1.3 Model 4234 Power Supply Unit – Fig. 4.3



Caution. The unit must be located in the safe area of the application plant in a sheltered interior environment.

The power supply unit has 4 fixing lugs and should be mounted on a suitable vertical surface. The installation dimensions are shown in Fig. 4.3.

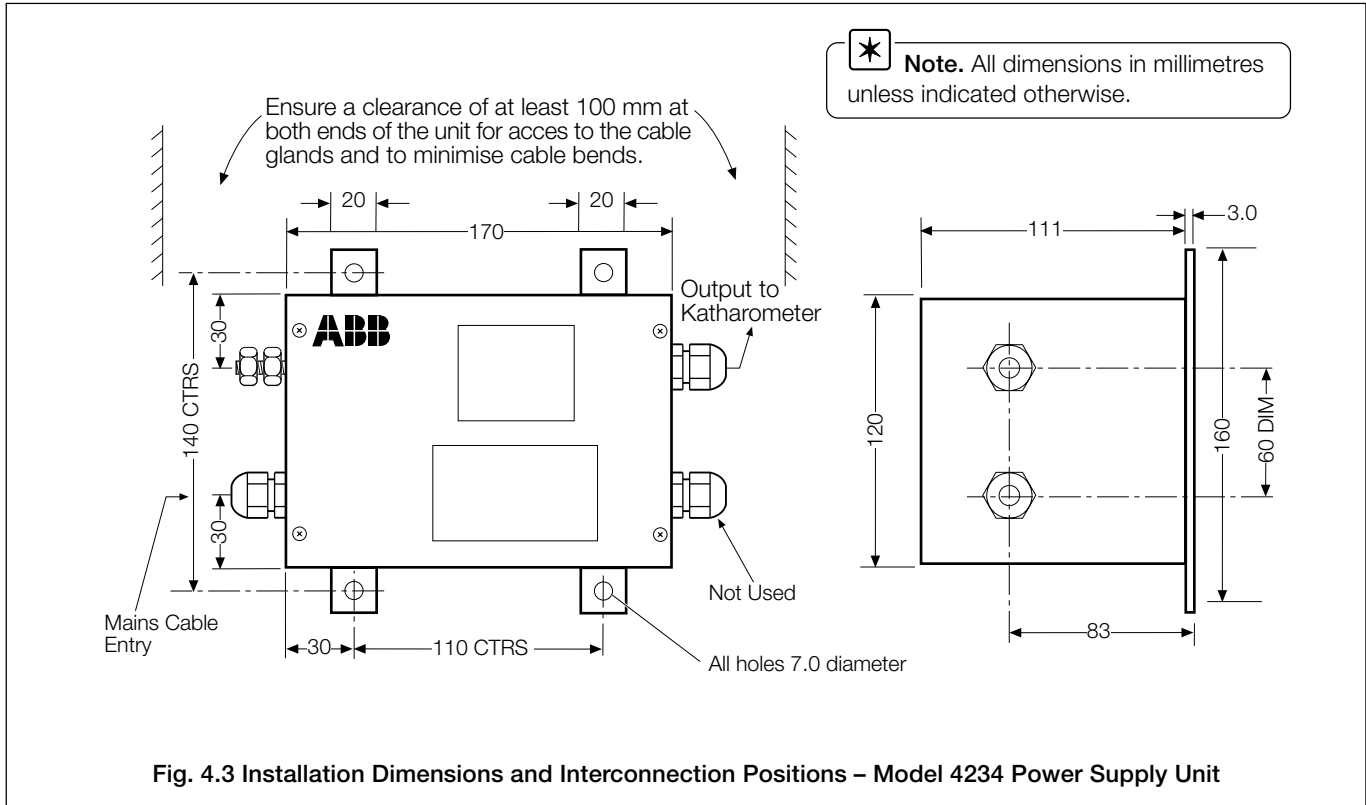

4.1.4 Cubicle Mounted System – Figs 4.4 and 4.5

The cubicle must be located in a safe area of the application plant and either mounted on the base using four M10 fixings, or to a vertical surface using the four fixing brackets. on the back-plate.

Overall dimensions of the cubicle are given in Fig. 4.4 and the principal base case components are shown in Fig. 4.5.

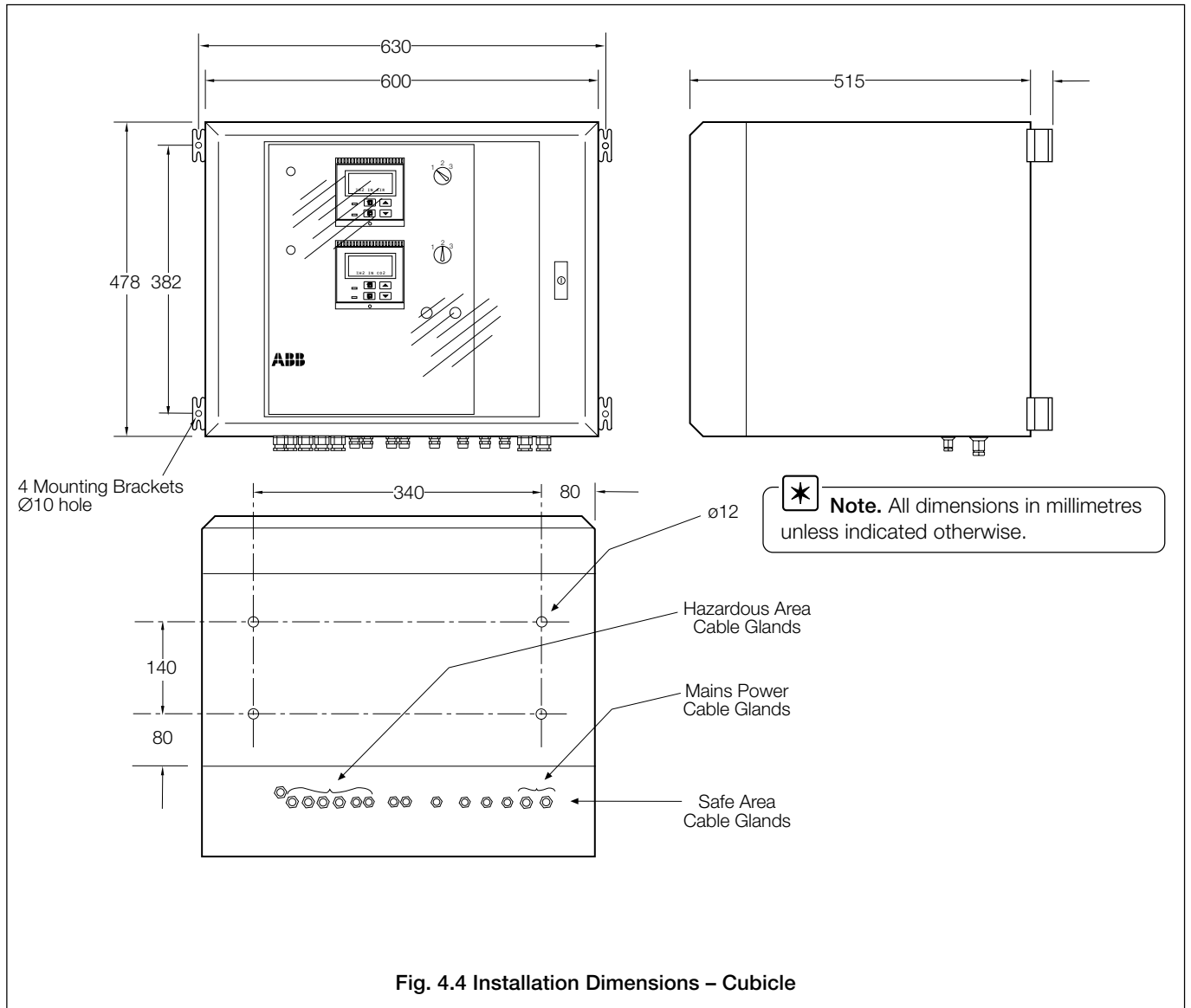

...4 MECHANICAL INSTALLATION

4.2 Sample Gas Interconnections



Warning. A hazardous mixture of hydrogen in air could develop in the event of leakage from the sample gas system. Katharometer Analyzer panels should be located in a ventilated area.

The sample pressure must not exceed the value given in Section 13.

The incoming sample gas temperature must not exceed the temperature given in Section 13. Ideally the sample gas temperature should be allowed to reach ambient temperature before entry to the Katharometer unit.

If there is a risk of significant particle contamination, a suitable 1 μ m filter unit should be incorporated in the system before the sample gas enters the Analyzer system.

Compression couplings are supplied at the sample inlet and outlet to the katharometer panel. These couplings are suitable for connecting 8mm (Model 006540 203) or 6mm (Model 006548 000) outside diameter metal tube. It is recommended that stainless steel tube is used.

The complete tubing system should be tested for leaks in accordance with the requirements of the responsible authority.

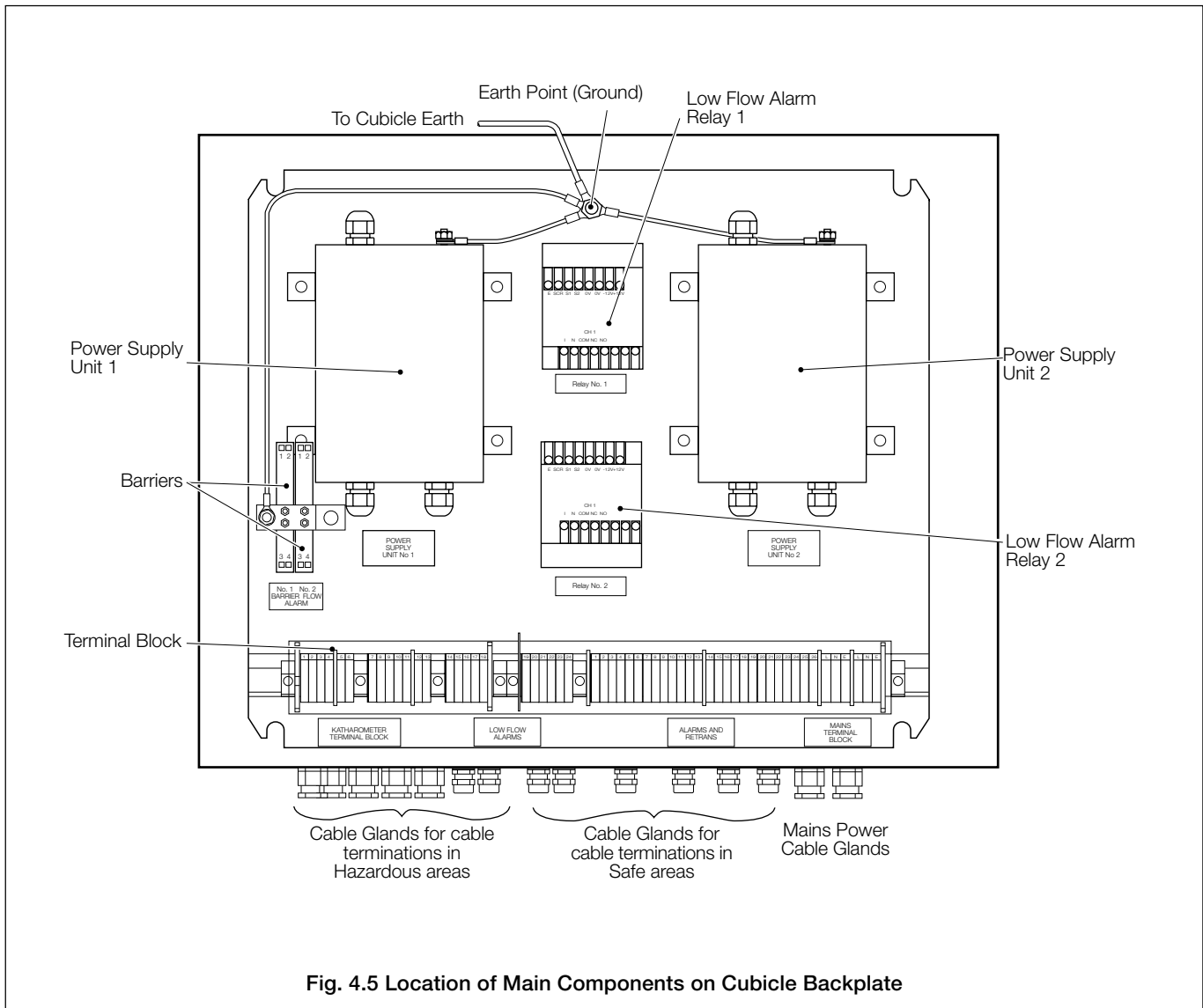

Fig. 4.5 Location of Main Components on Cubicle Backplate



Warning.

- Equipment in this system operates on AC mains supply voltage electricity. Suitable safety precautions must be taken to avoid the possibility of electric shock.
- Although certain instruments are fitted with internal fuse protection, a suitably rated external protection device, either a 3A fuse or miniature circuit breaker (MCB), must also be fitted by the installer.
- The proper electrical connections and wiring standards must be achieved to establish the intrinsic safety of the system, as certified.
- AC input, intrinsically safe DC output and non-intrinsically safe wiring must all be routed separately.

5.1.1 Model 6553 Gas Monitor – Fig. 5.2



Warning. No connections must be made to the hazardous area terminals (Terminal Blocks TB5 & TB6) other than as specified in wiring diagram Fig. 5.3. The appropriate cable requirements must be also satisfied.

Remove the outer case from the back of the unit to gain access to the terminal blocks.

The electrical connections are made through the bottom of the unit into the terminal blocks immediately above them. See Fig. 5.2.

The alarm and signal outputs on terminal blocks TB3 & TB4, may be connected as required. The availability of signal outputs vary with the particular 6553 system. Refer to Fig. 5.3 for details.

Make the wiring connections in accordance with the information given in the wiring diagram Fig. 5.3 and Section 5.1.

See Fig. 5.4 for connections to cubicle-mounted monitor.

Fig. 5.1 shows the interconnecting wiring requirements for the gas Analyzer system, which must be strictly observed. Details of cable requirements, which must be strictly adhered to, are also given – see Section 5.2.1.

After completing the wiring, check that the continuity earthing (grounding) and isolation of all circuits is to the required local electrical standards for intrinsically safe circuits.

The separate units of the Analyzer system must be interconnected as shown in Sections 5.1.1, 5.1.2 and 5.1.3.

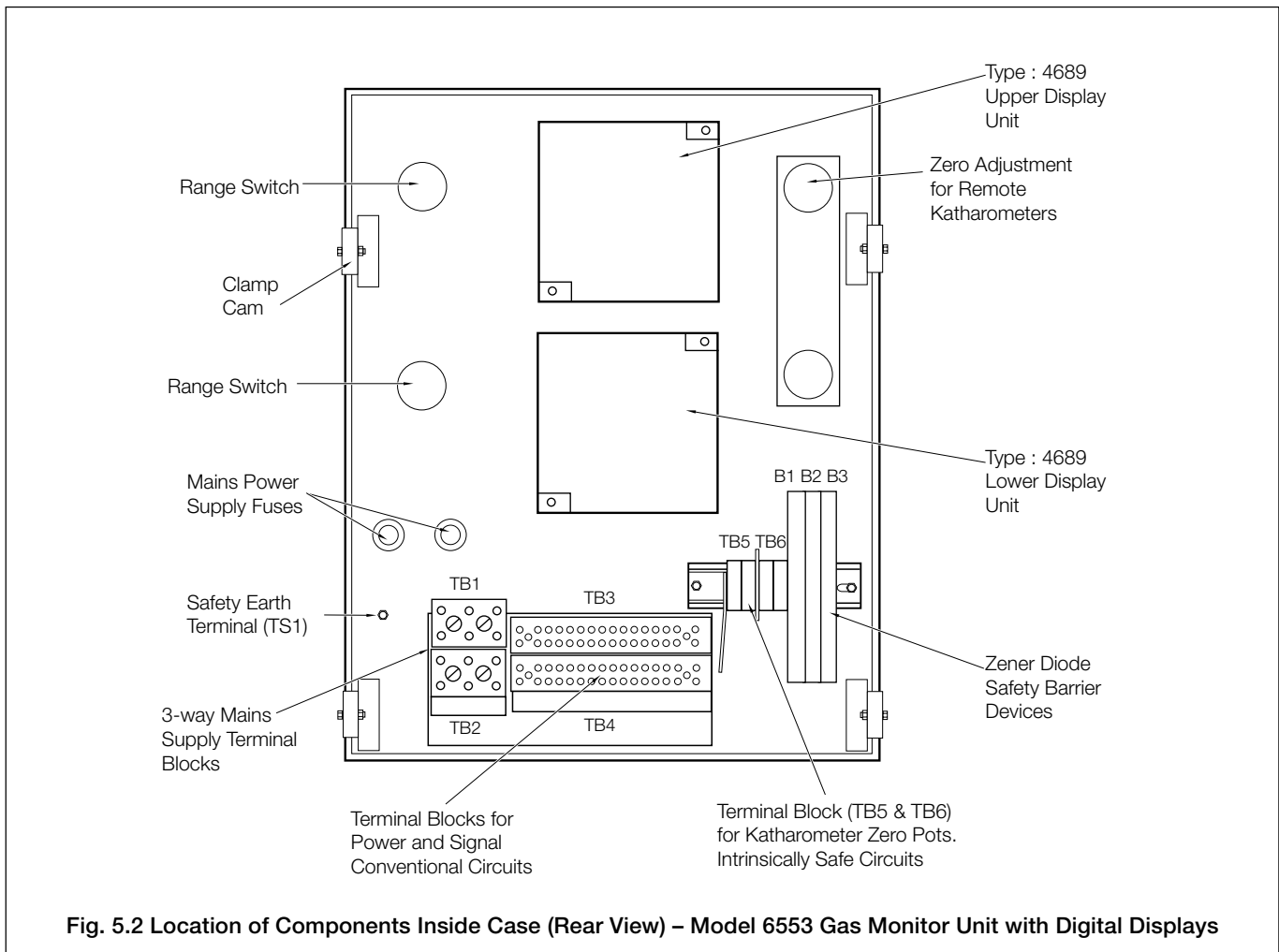

Fig. 5.2 Location of Components Inside Case (Rear View) – Model 6553 Gas Monitor Unit with Digital Displays

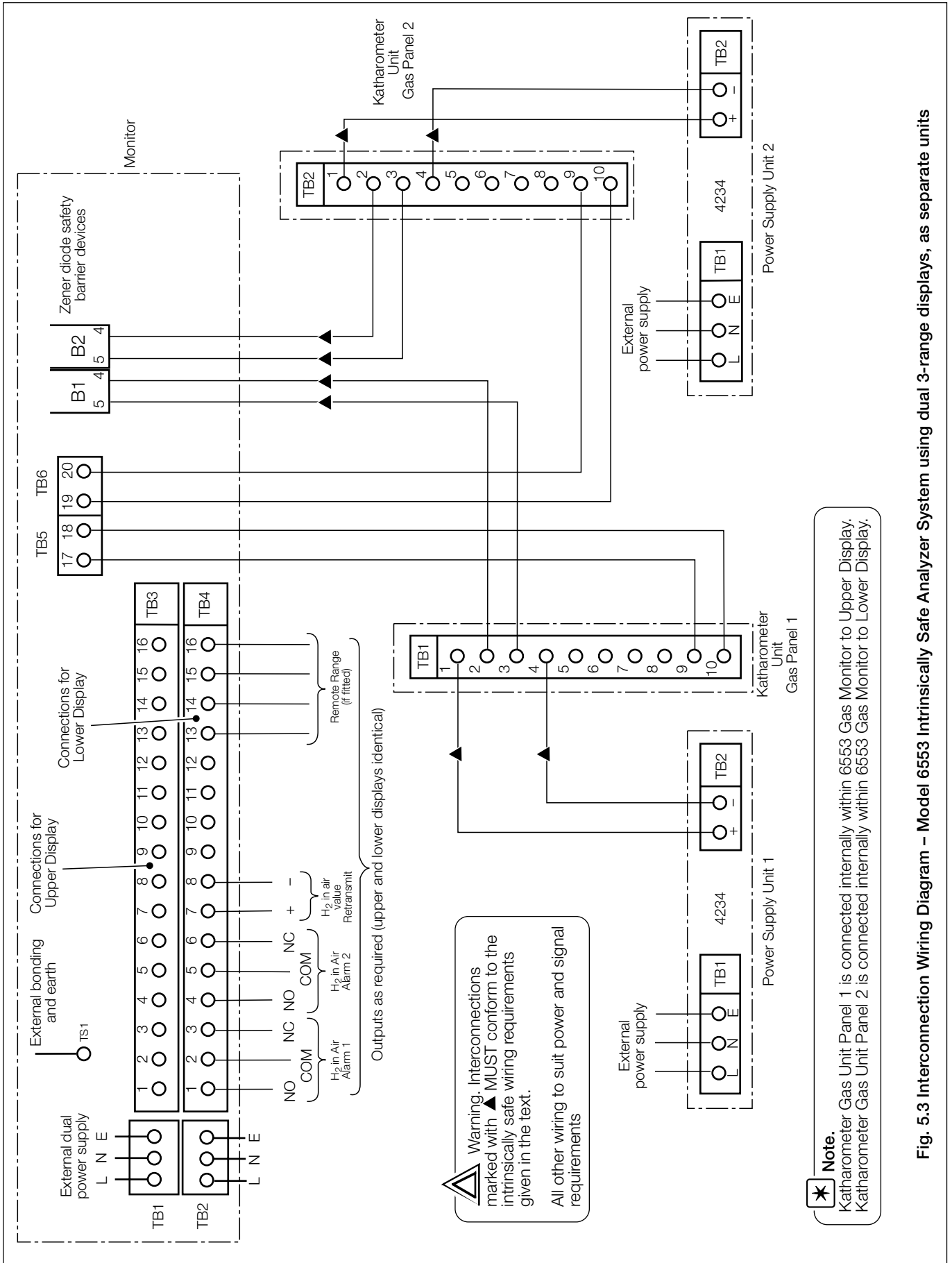

Fig. 5.3 Interconnection Wiring Diagram – Model 6553 Intrinsic Safe Analyzer System using dual 3-range displays, as separate units

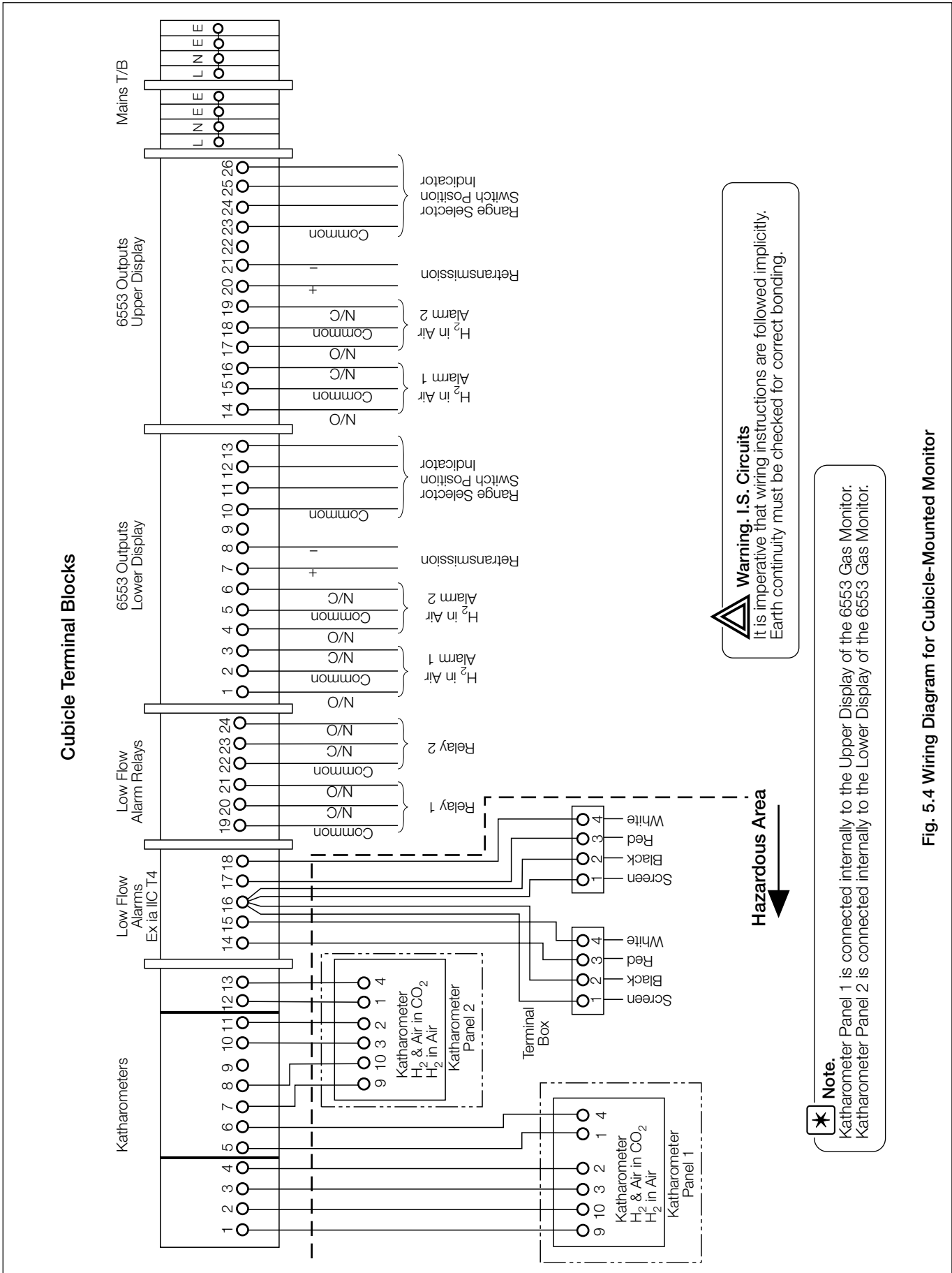

Fig. 5.4 Wiring Diagram for Cubicle-Mounted Monitor



Caution. The integrity of the fail-safe operation of the zener diode safety barrier devices depends on a Safety Earth connection which must not have a resistance greater than $1R0$ to the application plant earth (ground).

Make the Earth (Ground) and **Safety Earth** connection at the stud (TS1) – see Fig. 5.2.

On completion of wiring and checks, replace the outer case and secure the clamping brackets to the mounting panel.

5.1.2 Model 006540 203 and 0065480 00 Katharometer Analyzer Panel

Access to terminals

Make the electrical connections to the Gas Monitor in accordance with the information given in wiring diagrams in Figs 5.3, 5.4 and 5.5 and Section 5.2.

- 1) Remove four screws in the cover of the katharometer unit.
- 2) Remove cover to access the terminal block (TB1) inside.

The electrical connections are made at the terminal block (TB1) via the cable gland, or any replacement gland to suit the intrinsically safe wiring requirements. When the appropriate interconnections have been made, if remote zero is to be used, remove the 510R dummy remote zero resistor from across terminals 9 and 10 and set the zero adjustment potentiometer on the katharometer to the approximate mid-point.

Replace the cover when wiring is complete.

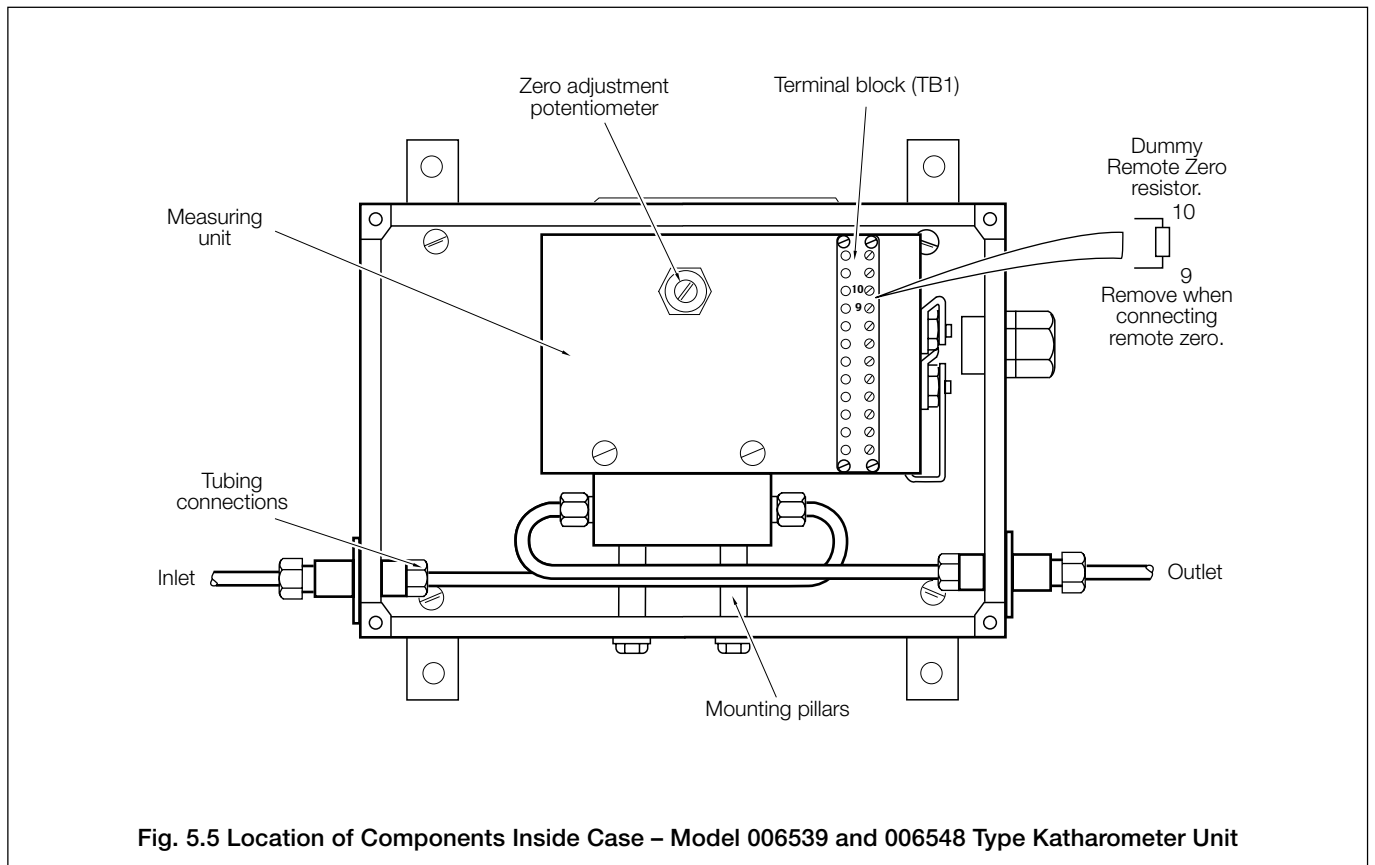

...5 ELECTRICAL INSTALLATION

5.1.3 Model 4234 Power Supply Unit – Fig. 5.6



Warning. Do **NOT** connect mains supply to the power supply unit with the output terminals on open circuit.



Caution. Ensure that the power supply unit is correct for the mains supply voltage available. A nominal 115V unit cannot be adapted for use with a nominal 230V supply, or the other way around.

Remove the cover of the unit to gain access to the terminal blocks inside.

Locate the terminal block (TB1) adjacent to the transformer T1 and ensure the correct transformer tapping is used for the incoming mains supply, i.e.

- link from tapping 6 to 10 for 230 V, or
- link from tapping 8 to 10 for 115 V.

Make electrical connections in accordance with the information given in the wiring diagrams Figs 5.1 and 5.3 and Section 5.2.1.

The electrical connections are made at terminal blocks TB1 and TB2 through the appropriate cable gland, or any replacement gland to suit intrinsically safe wiring requirements. Secure the incoming cable by the cable clips adjacent to the terminal blocks.

Replace the cover when wiring is complete.

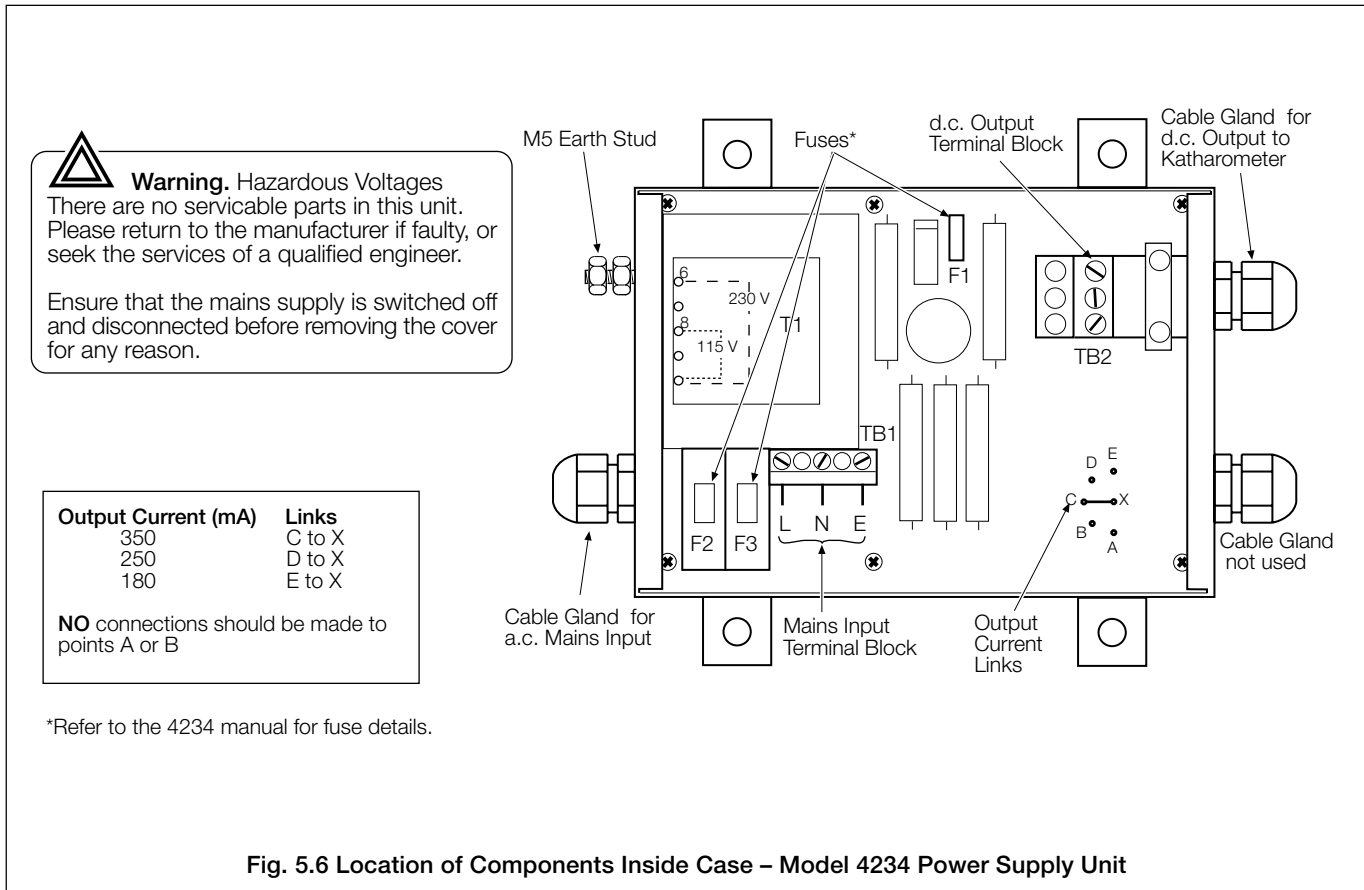

5.2 Intrinsically Safe Requirements

These requirements relate to the interconnecting wiring made to and from Model 6540 203 and 6548 000 Katharometer Analyzer Panels in the hazardous area, and those for remote ancillary items connected to the system.

5.2.1 Cable Requirements

The interconnecting cables between the various units of the gas analysis system are subject to stringent limitations because of the requirements of the intrinsic safety certification. These are listed below and detailed in Fig. 5.1.

All cables entering the **hazardous** area must be kept separate from cables in the **safe** area. Cables entering the **hazardous** area must not be run with other cables, and terminations must have an earthed screen to separate them from connections for other circuits. The detailed requirements are as follows:

1) Connections between Model 006540 203 or 006548 000 Katharometer Analyzer Panels and the 4234 PSU.

All cables from the Katharometer in the hazardous area must have an inductance/resistance ratio not exceeding $20\mu\text{H}/\Omega$, (for Group IIC gases). There is a further requirement that the maximum loop resistance of this interconnecting cable is limited to 1.5Ω . This may place a limitation on the length of the total cable run.

Single sheathed conducting cables should be twisted together to reduce their mutual inductance, and routed separately from cabling for non-intrinsically safe circuits in the safe area.

2) Connections between Model 006540 203 or 006548 000 Katharometer Analyzer Panels and Model 6553 Gas Monitor Unit.

Katharometer to display unit cables, carrying the output signals through zener barrier units inside the monitor unit, are subject to of a maximum inductance/resistance ratio of $20\mu\text{H}/\Omega$ (for group IIC gases). These wires are indicated by a ▲ in Fig. 5.3.

5.2.2 Recommended Cables

The choice of wiring cable is restricted due to the limitations imposed by the certification parameters – see Notes 2a, b and c in Fig. 5.1.

Cables manufactured to DEF STAN 61-12 Part 5 should comply, but care should be taken over the number or cores included in the cable. As can be seen, there is a significant difference between the 2-core and 6-core cables. The diameter over the screen in the 6-core cable is greater than that of a 2-core, and this diameter affects both the inductance and capacitance values.

The values of a typical DEF STAN 61-12 Part 5 cable from:

Permanoid Ltd
Hulm Hall Lane
Manchester, M40 8HH
UK

Telephone: 0161 2056161

Facimilie: 0161 2059325

E-mail: sales@permanoid.co.uk

Website: www.permanoid.co.uk

	2-core	6-core
Inductance ($\mu\text{H}/\text{metre}$)	0.325	0.467
Capacitance (pF/metre)	190	143
L/R ($\mu\text{H}/\Omega$)	8.6	11.4
Test voltage	2kV AC for one minute	
Rated voltage	440V RMS	

5.2.3 Installing Remote Ancillary Items

Any indicator/controllers, or other electrical equipment, connected to TB1 of the Model 6553 Gas Monitor Unit must not be supplied from, nor contain, a potential source greater than 250V DC or 250V RMS with respect to earth.

5.2.4 Full Intrinsically Safe Requirements

For systems to be modified or used with other gases the full ATEX requirements must be complied with as follows:

- 1) The total Capacitance and Inductance or Inductance to Resistance ratio (L/R) of the cables connecting the katharometer unit to the hazardous area terminals of the monitor unit (TB2) and power supply unit terminals (TB1) must not exceed the values given in Fig. 5.1.
- 2) Any junction boxes used in the hazardous or safe areas must conform to ATEX Directive 9/94/EC, specifically clauses 6.1 and 6.3.1 of EN50020:1994.

When the gas Analyzer system has been correctly installed in accordance with the requirements for intrinsic safety given in Section 5.2, carry out the following setting-up in Section 6.

6 SETTING UP

6.1 Katharometer Analyzer Panel – Filling the Drying Chamber – Fig. 6.1

- 1) Remove the drying chamber on the katharometer Analyzer panel by unscrewing the large knurled nut at the base of the chamber. Pull the chamber down and out of the sealing groove to remove it from the panel.
- 2) Open a container of fresh granular anhydrous calcium sulphate or calcium chloride, immediately fill, and prepare to replace, the drying chamber.

* **Note.** The capacity of the drying chamber is about 140ml. To fill the chamber, approximately 100g of desiccant is required.

- 3) Replace the drying chamber in its sealing groove and reposition the chamber to enable it to be secured and sealed by hand tightening the knurled nut.
- 4) Carry out an approved leak testing procedure before passing sample gas through the system.

6.2 Setting Sample Flow

When all tubing interconnections have been made and external parts of the sample system checked for leaks, the suggested procedure is as follows:

- 1) Arrange to supply calibration quality carbon dioxide gas through the gas Analyzer system at the normal working pressure of the application plant and within the limits given in Section 13.



Caution. Testing for leaks with carbon dioxide may not be considered an adequate check of gas tight integrity in respect of the more penetrating hydrogen gas. Consideration may be given to the use of a gas, such as helium, which has penetrating properties nearer to that of hydrogen.

- 2) Slowly open the metering valve to give a nominal flowrate of gas of 100 to 150ml min⁻¹. Do not exceed the maximum flowrate given in Section 13.
- 3) Set the flowrate and shut off the calibration gas external to the Analyzer system.
- 4) Repeat this procedure for each katharometer Analyzer panel, as required.

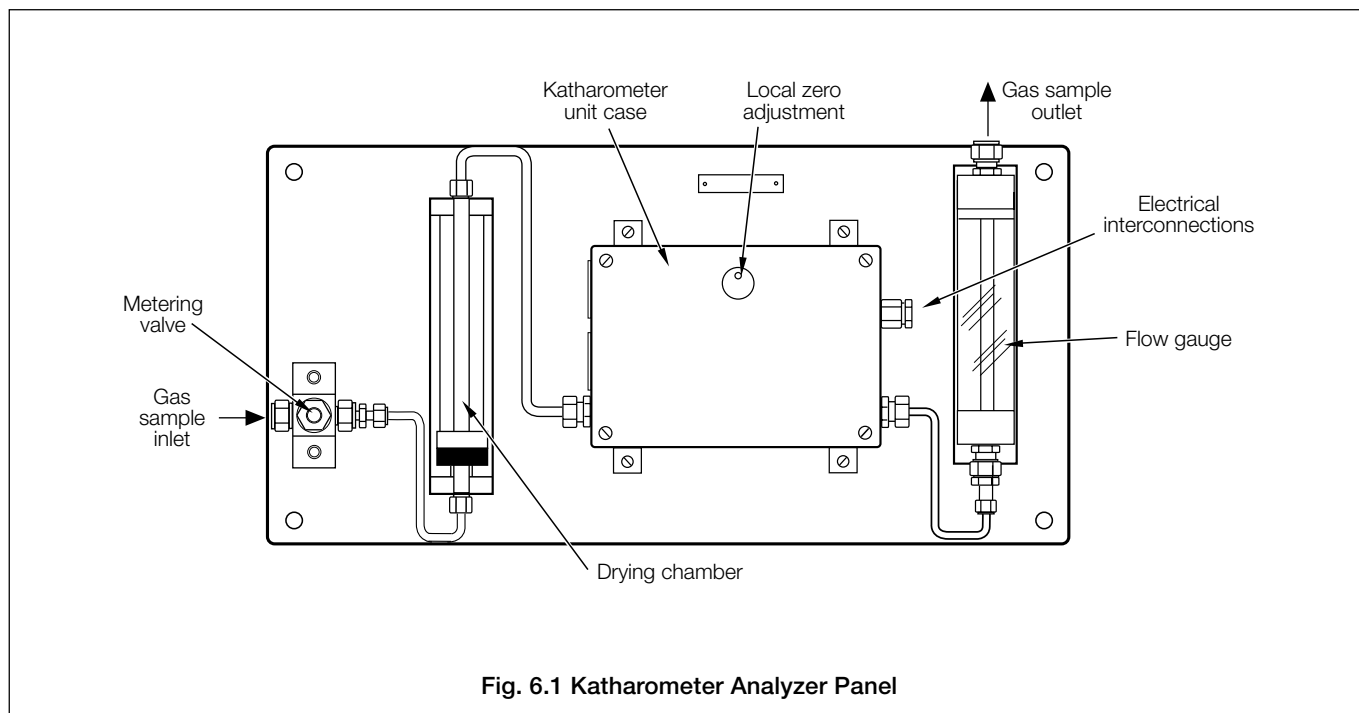

Fig. 6.1 Katharometer Analyzer Panel

6.3 Electrical Checks

Carry out the following electrical checks:

6.3.1 Power Supply Unit Output



Warning. This unit is part of the certified intrinsically safe system. Appropriate safety precautions must be taken to prevent any incendive electrical discharges in the hazardous area when carrying out this task.

Testing the output may only be carried out with the hazardous area cable disconnected.

- 1) Electrically isolate the PSU.
- 2) Remove the cover from the PSU.
- 3) Disconnect the output wires to the hazardous area at terminals TB2+ and TB2-.



Warning. Ensure that proper electrical safety precautions are taken at all times when undertaking this procedure.

- 4) Switch on the PSU and check that the output measures 350mA into a 14Ω load.
- 5) On completion of tests isolate the unit and reconnect the output wires to the hazardous area.
- 6) Replace the cover on the unit.

6.3.2 Zener Diode Safety Barrier Devices

The zener diode safety barrier devices (MTL 7055ac) in the 6553 Monitor Unit are checked at the time of manufacture. To ensure absolute safety when fitting a new instrument, check that the barriers in the monitor are properly earthed by carrying out a routine test before using the Analyzer system.



Warning.

- This unit is part of the certified intrinsically safe system. Appropriate safety precautions must be taken to prevent any incendive electrical discharges in the hazardous area when carrying out this task.
- If these tests reveal a faulty zener barrier, the barrier **MUST** be replaced by a new unit. The barrier is a sealed unit and no repair is permitted. The correct zener barriers are certified intrinsically safe and conform to the ATEX Directive 9/94/EC, certificate number BAS 99 ATEX 7285.

6.3.3 Checking System Earth

Check that the resistance between earth terminals on the Analyzer system and the application plant system safety earth does not exceed 1Ω.

7 CONTROLS & DISPLAYS

7.1 Displays – Fig. 7.1

The displays, mounted in the 6553 panel, comprise a 5-digit, 7-segment digital upper display line and a 16-character dot-matrix lower display line. The upper display line shows actual values of hydrogen purity, hydrogen in air, air in carbon dioxide, alarm set points or programmable parameters. The lower display line shows the associated units or programming information.

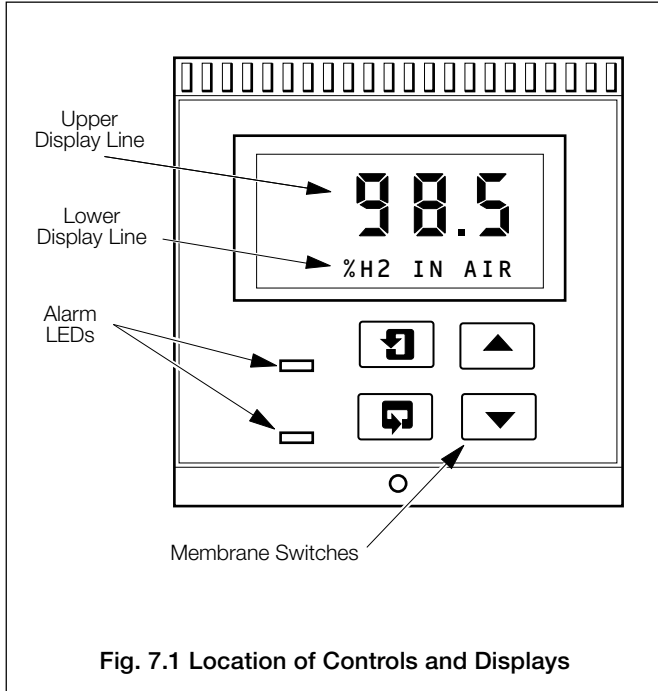
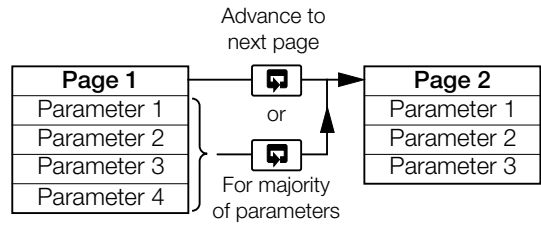
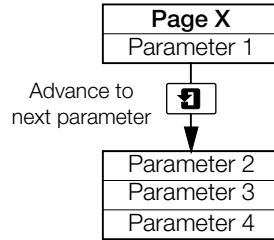

Fig. 7.1 Location of Controls and Displays

7.2 Switch Familiarization – Fig. 7.1 and 7.2



A – Advancing to Next Page



B – Moving Between Parameters

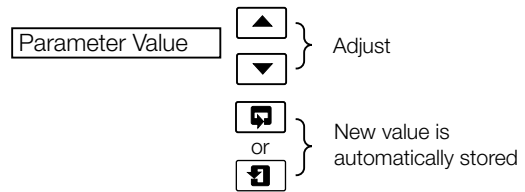

C – Adjusting and Storing a Parameter Value

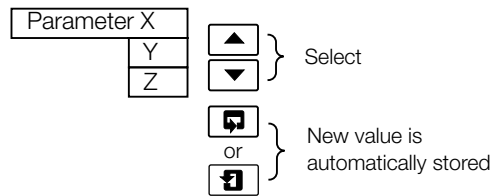

D – Selecting and Storing a Parameter Choice

Fig. 7.2 Function of the Membrane Switches

8 START-UP



Warning. When the apparatus is connected to its supply, terminals may be live, and the opening of covers or removal of parts (except those to which access may be gained by hand) is likely to expose live parts.

8.1 Instrument Start-Up

In normal operation the instrument displays the Operating Page which is a general use page in which parameters are viewed only and cannot be altered. Any changes to the operating parameters are implemented using the switches as described in 7.2 Switch Familiarisation. To alter or program a parameter refer to Section 10. A 5-digit Security Code is used to prevent unauthorised access to programmable parameters. The value is preset at 00000 to allow access during commissioning but should be altered to a unique value, known only to authorized operators, as described in the Setup Outputs Page.

When all the required wiring connections and electrical checks have been correctly made, the power supplies to the various units may be switched on as follows:

- 1) Switch on the supply voltage to the PSU.
- 2) Switch on the supply voltage to the 6553 Monitor unit.

8.2 Alarm Set Points

8.2.1 Type of Alarm Action

The alarm relay coil is energized during normal non-alarm relay states and is de-energized upon recognition of an alarm condition, thereby providing 'fail-safe' alarms. i.e. with Alarm 1 set point = 95.0%, when the display is indicating greater than 95.0% (plus hysteresis), then Alarm Relay 1 is energized and Alarm 1 LED is OFF. When the display indicates less than 95.0% (minus hysteresis), then Alarm Relay 1 is de-energized and Alarm 1 LED is ON. This operating mode ensures that, in the event of a mains power failure, an alarm condition is signalled. Repeat process for Alarm Relay 2 set point = 90.0%.

8.2.2 Hydrogen alarm Set Point

It is suggested that the hydrogen alarm set-points should be based on a reducing percentage of hydrogen as it is displaced by air entering the application plant. This can be achieved by setting Alarm 1 and Alarm 2 to give ample warning of the development of a potentially explosive mixture. Factory settings are Alarm 1 = 95.0% and Alarm 2 = 90.0%.

The procedure is as follows:

Access the programming pages (Section 10) and input the alarm set-points in accordance with the information given in Set Up Outputs Page. The hydrogen alarm set point can only be set with the selector switch in position 1.

8.3 Electrical Calibration

The instrument is factory calibrated for electrical voltage signal input. No adjustment is normally necessary for proper functioning of the purge gas monitor. If electrical calibration is required, a voltage source capable of supplying 10.00 mV and 250.00 mV is needed. The katharometer input to the monitor unit should be disconnected and the voltage source signal applied according to the instructions in the Electrical Cal programming page (see Section 10).



Note. The 4600 Series instruments incorporate a two point calibration sequence requiring both zero and span inputs for a calibration. It is not possible to adjust either the range zero or the range span scale points independently.

8.4 Gas Calibration

8.4.1 Introduction

Before putting the system on-line, it is recommended that a calibration check for the 'zero' reading is made using calibration standard sample gas.

The 'zero gas' is permanently marked on the data plate of the katharometer unit. This gas when passed through the katharometer gives a zero millivolt output. To provide a fail-safe condition the zero gas is 85% hydrogen in nitrogen mixture so that if power is lost to the katharometer, an alarm condition will occur at the monitor unit.

Full scale output from the katharometer is obtained by a 100% hydrogen gas sample and no adjustment of the katharometer output is normally required. The maximum signal for the full scale reading is sealed during manufacture and should not be altered by users.

With the katharometer correctly adjusted using the 'zero gas' hydrogen in nitrogen mixture carbon dioxide and air mixtures are correctly displayed when the selector switch is in the appropriate position.

8.4.2 Gas Range Calibration



Warning. Test for leaks in accordance with the requirements of the responsible authority after making any hydrogen connections.



Note. The procedure outlined here should not normally be necessary as the ranges have been set at the factory.

1) Select Range 1

Pass an 85% H₂/15% N₂ gas mixture through the katharometer and allow the reading to stabilize. Adjust the katharometer zero potentiometer or remote zero (if fitted) to give a reading of 85% H₂ in air.

- 2) Pass 100% H₂ through the katharometer and allow the reading to stabilize. If necessary adjust the katharometer span potentiometer (R7) to read 100% H₂ reading.

- 3) **Select Range 3**
Pass 100% CO₂ through the katharometer and allow the reading to stabilize. Adjust the katharometer span potentiometer (R7) to give 0% air in CO₂.
- 4) Pass 100% air through the katharometer and allow the reading to stabilize. Adjust katharometer span potentiometer (R7) to give 100% air in CO₂ (only if the reading is greater than 100%).
- 5) **Select Range 1**
Pass 100% H₂ through the katharometer and allow the reading to stabilize. Adjust the katharometer zero potentiometer or remote zero (if fitted) to give a reading of 100% H₂ in air.
- 6) Repeat steps 3) to 5) and adjust as necessary.

9.1 Normal

During normal operation the Model 6553 Gas Analyzer System is used to indicate the purity of hydrogen used as a coolant. The displays shows the percentage of hydrogen in air, which should be safely in excess of the explosive limit at the hydrogen rich end.

There are no routine adjustments required to the gas Analyzer system after completion of start-up procedures and putting on-line in monitoring mode. The system only requires minor adjustments to the metering valve to maintain the required flowrate and the carrying out of safety routines.

A summary of the functions and status of the system for the different range selector switch positions is shown in Table 9.1.

9.1.1 Purging of Hydrogen Coolant Gas

Initially, inert purge gas (carbon dioxide) is introduced into the system. When the hydrogen concentration is safely below the explosive limit, air is introduced into the system to completely displace the other two gases.

The Model 6553 Gas Analyzer System provides all the necessary indications and output signals to enable this operation to be carried out safely.

In respect of the operation of the gas Analyzer system(s), the procedures are as follows:



Warning. Suitable safety procedures apply to the operation of gas cooling and sample systems.

- 1) Select position (2) of the range selector switch on the monitor unit. This causes the display units to indicate and have the functions given in Table 9.1.
- 2) Commence the purging operation.
- 3) When the changeover to introduce air into the application plant is made, select position (3) of the range selector switch on the monitor unit. This causes the display unit to indicate and have the functions given in Table 9.1.

Range Selector Switch Position	Upper Display Line		Lower Display Line		Alarm 1 + 2 Set Points and Retransmission
	Actual Display	Function	Actual Display	Function	
(1)	xxx.x	Variable Value	%H2 IN AIR	Hydrogen Purity	As required
(2)	xxx.x	Variable Value	%H2 IN CO2 or Ar	Purge Gas	Inhibit
(3)	xxx.x	Variable Value	%AIR IN CO2 or Ar	Purge Gas	Inhibit

Table 9.1 Functions and Status of Display Units for Different Range Selector Switch Positions

9.1.2 Filling with Hydrogen Coolant Gas

This procedure is a reversal of the purging procedure.

Initially, inert purge gas (carbon dioxide) is introduced into the application plant until the air content is safely below the explosive limit for air in hydrogen. When this limit is reached, hydrogen is gradually introduced into the system to displace the other two gases.

With respect to the operation of the gas Analyzer system, the procedure is as follows:



Warning. Suitable safety precautions will apply to the operation of the gas cooling and sample systems.



Note. For reasons of accuracy it is recommended that the filling operation commences within 24 hours of carrying out the calibration procedure.

- 1) Select position (3) of the range selector switch of the monitor unit. This causes the display units to indicate and have the functions given in Table 9.1.
- 2) When the changeover to introduce hydrogen into the application plant is made, select range (2) of the range selector switch on the monitor unit. This causes the display units to indicate and have the functions as given in Table 9.1.
- 3) When the display indicates that hydrogen filling is complete, position the range selector switch at (1). The hydrogen measurement Analyzer system is now on-line in monitoring mode.

10 PROGRAMMING

* **Note.** The following programming pages apply to BOTH 4689 display units.

* **Note.** Programming of the **Language** page, **Set Up Output** page and the **Electrical Calibration** page can only be carried out with Range 1 selected.

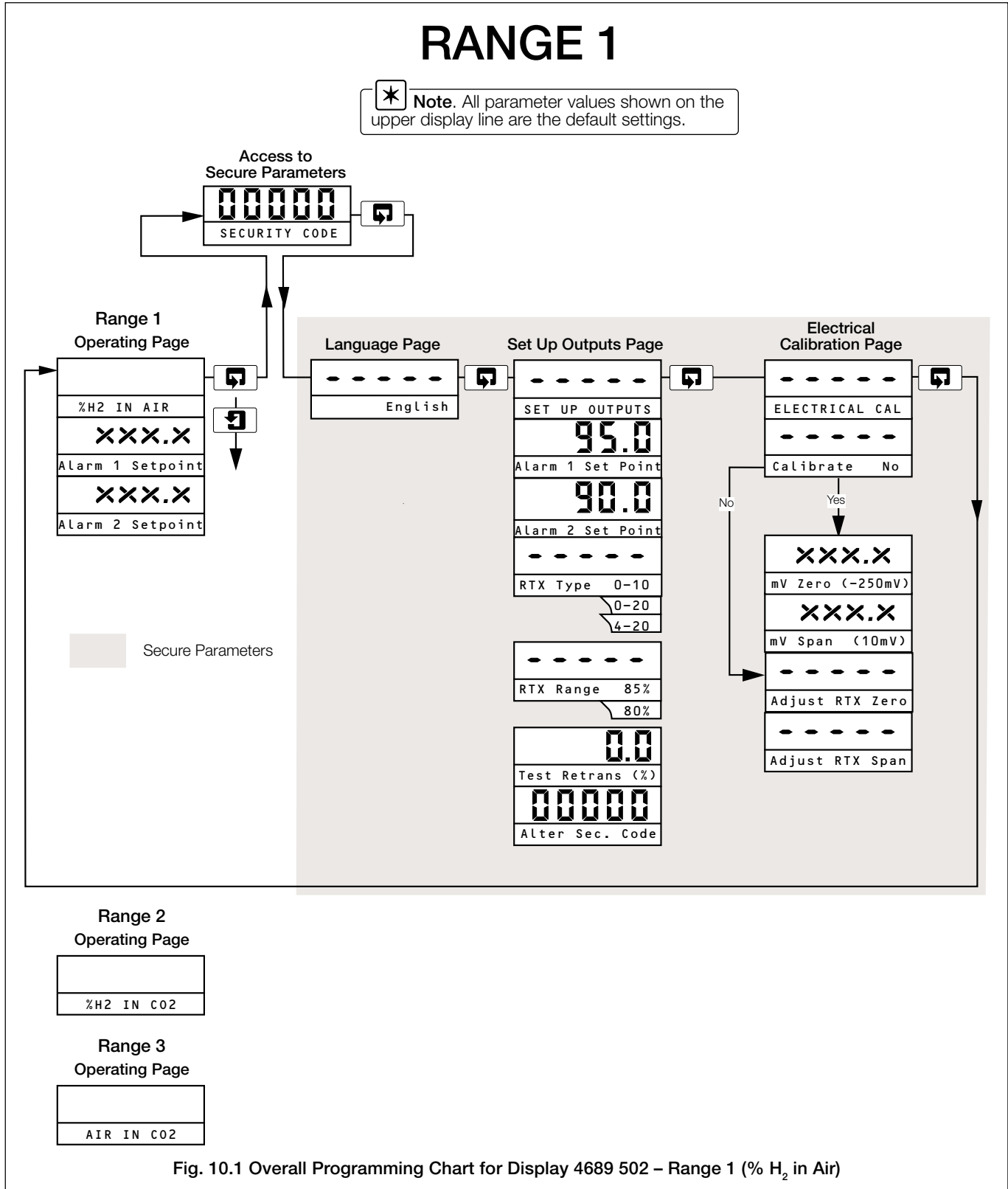



Note. Programming scrolls only available when Range 1 selected.

10.1 Range 1 (%H₂ in Air)

10.1.1 Access to Secure Parameters (Range 1)

A 5-digit code is used to prevent unauthorized access to the secure parameters.

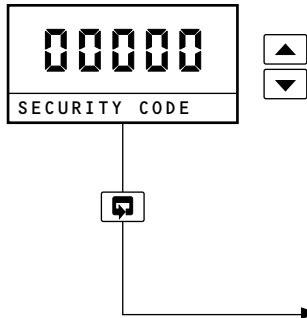

Security Code

Enter the required code number, between 00000 and 19999, to gain access to the secure parameters. If an incorrect value is entered, access to subsequent programming pages is prevented and the display reverts to the **Operating Page**.



Note. The security code is preset at '00000' to allow access during commissioning but should be altered to a unique value, known only to authorized operators – see **Set Up Outputs Page**.

Advance to **Language Page**.

10.1.2 Language Page

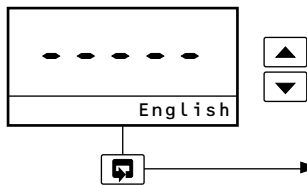

Language Page

Select the required language for the display.

Advance to the **Set Up Outputs Page**.

10.1.3 Set Up Outputs Page

Note. Programming scrolls only available when Range 1 selected.

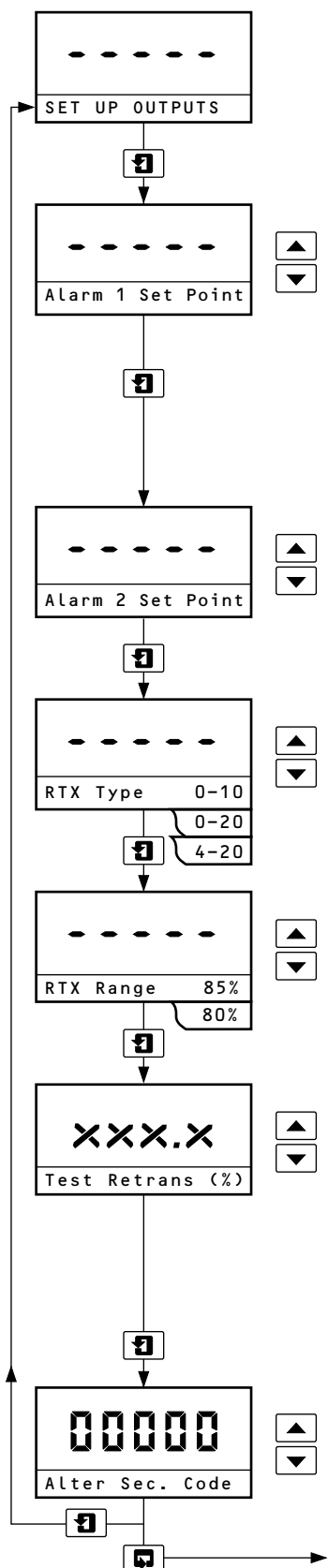

Page Header – **SET UP OUTPUTS**

Advance to next parameter.

Alarm 1 Set Point

The set point band is defined as the actual value of the set point plus or minus the hysteresis value. The hysteresis value is $\pm 1\%$ of the full span value displayed in the **Electrical Calibration Page**. Alarm action occurs if the input value is above or below the set point band. If the input moves within the set point band, the last alarm action is maintained.

The **Alarm 1 Set Point** can be set to any value within the input range being displayed. The decimal point position is set automatically. The alarm LEDs are illuminated in the alarm condition.

Alarm 2 Set Point

See notes in Alarm 1 Set Point.

Advance to next parameter.

Retransmission Output Assignment

Select current output (mA).

Advance to next parameter.

RTX Range

The retransmission signal (4 to 20mA) can be selected to be ranged 85 to 100% H₂ in Air or 80 to 100% H₂ in Air. This option is only available with the range switch in position 1.

Advance to the next parameter.

Test Retransmission Output

The instrument automatically transmits a test signal of 0, 25, 50, 75 or 100% of the retransmission range. The % test signal selected is shown on the upper line of the display.

Example – for the range 4 to 20mA and 50% retransmission test signal, 12mA is transmitted.

Select the required retransmission test signal.

Advance to the next parameter.

Alter Security Code

Set the security code to a value between 00000 and 19999.

This value will then have to be entered to regain access to the secure parameters.

Advance to **Electrical Calibration Page**.

10.1.4 Electrical Calibration Page

Note. Programming scrolls only available when Range 1 selected.

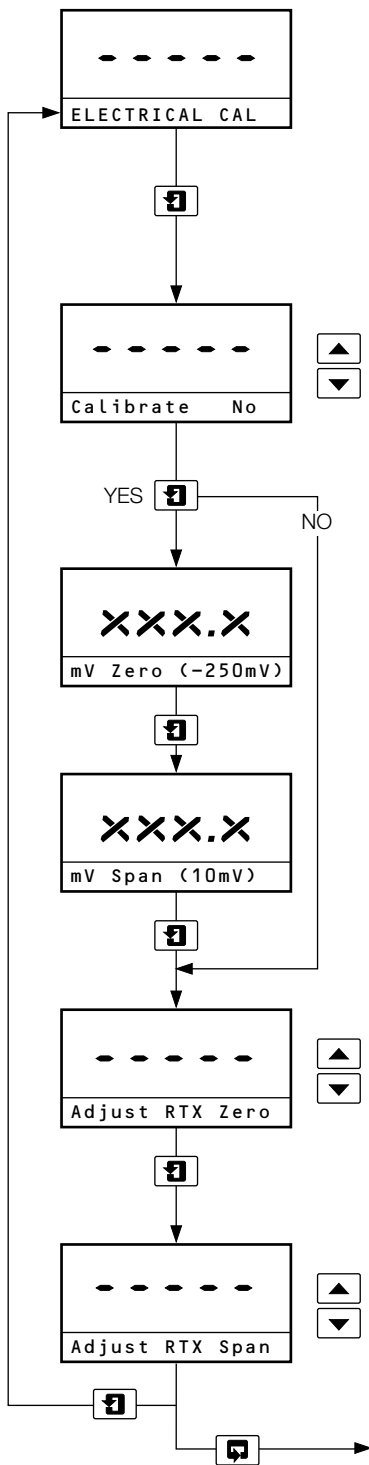

Page header – **ELECTRICAL CAL**

Notes.

- 1) The 4600 Series instruments incorporate a two point calibration sequence requiring both zero and span inputs for a calibration. It is not possible to adjust the range zero or the range span scale points independently.
- 2) The instrument is fully calibrated before despatch and should not normally require further calibration.

Select Calibration

Select the calibration requirement using the scroll up or scroll down keys.

Calibrate **No** (default) skips to Adjust RTX Zero frame.

Calibrate **Yes** enables zero and span electrical calibrations to be carried out.

Advance to next parameter.

Calibration Range Zero

Apply a signal input equivalent to range zero (-250.00mV). Allow the instrument display to stabilize.

Advance to next parameter.

Calibration Range Span, H₂-AIR

Apply a signal input equivalent to range span (+10.000mV). Allow the instrument display to stabilize.

Advance to next parameter

Adjust Retransmission Zero

Adjust the retransmission zero (4.00mA) to the correct value. The retransmission zero signal will be either 85% or 80% H₂ in Air as selected in **Set Up Outputs Page**.

Allow the output signal to stabilize.

Advance to next parameter

Adjust Retransmission Span

Adjust the retransmission span (20.00mA) to the correct value. The retransmission span signal will correspond to 100% H₂ in Air.

Allow the output signal to stabilize.

Return to **Operating Page**.

11 MAINTENANCE



Warning.

- Each unit of this system forms an integral part of a certified intrinsically safe system. Appropriate safety precautions must be taken to prevent any incendive electrical discharges in the hazardous area when carrying out any of the following tasks.
- Equipment in this system operates on a.c. mains supply voltage electricity. Suitable precautions must be taken to avoid the possibility of electric shock.
- The maximum pressure and temperature specified for particular parts of the system must not be exceeded.

The katharometer unit and its associated equipment are designed for stable and accurate operation over long periods.

This section covers the requirements for fault finding, diagnostic tests and maintenance tasks.

11.1 General Maintenance

11.1.1 Pressure

The operation of the katharometer units is not affected significantly by changes in pressure providing that they are within the pressure limits given in Section 13.

11.1.2 Flow

The katharometer zero balance and sensitivity are independent of the sample flowrate, as the sample gas sensing system depends on molecular diffusion. However, the speed of response is affected by the flowrate. This means that the flow resistance of the drying chamber is a compromise between obtaining speed of response, and avoiding a rapid degradation of the desiccant.

11.1.3 Leaks

There is an inherent safety requirement that there are no leaks into or out of the sample system. Any leaks could also affect the correct operation of the katharometer unit.

11.1.4 Vibration

The katharometer unit tolerates reasonable levels of mechanically induced vibration. Pulsations due to unsteady sample flow can affect the katharometer filaments and cause errors due to excessive cooling.

11.1.5 Contamination

Contamination in the sample system can arise from oil or suspended particles, or from erosion of material from the sample system upstream of the katharometer unit.

11.1.6 Ambient Temperature

The calibration of the katharometer is not significantly affected by variations of the ambient temperature. Temperature changes can affect the sensitivity and reduce accuracy on sensitive ranges.

11.1.7 Bridge Current

The working current of the katharometer bridge is 350mA supplied from the PSU. This value must remain stable during normal operation as the katharometer output signal is approximately proportional to the cube of the bridge current.

11.2 Diagnostic Tests



Warning.

- These units are part of the certified intrinsically safe system. Appropriate safety precautions must be taken to prevent any incendive electrical discharges in the hazardous area when carrying out this task.
- Ensure that the proper electrical safety precautions are taken at all times when undertaking this procedure.

11.2.1 Checking Output of the PSU

Carry out the test procedure given in Section 6.3.1.

11.2.2 Checking Integrity of Zener Diode Safety Barrier Devices

Carry out the test procedure given in Section 6.3.2.

11.2.3 Checking the Katharometer Output

- a) Electrically isolate the monitor unit.
- b) Remove the outer cover from the katharometer unit.
- c) With the katharometer operating, check if the voltage across terminals TB1 – 1 and TB1 – 4 is not above 4V with 350mA passing. If the voltage is above this value it is likely that one or more filaments of the bridge is broken.
- d) With the katharometer operating, check that the voltage across terminals TB1 – 1 and TB1 – 4 is below 2.8V with 350mA passing. If the voltage is below this value and there is no zero adjustment available, it is likely that there is an accumulation of liquid within the katharometer block.
- e) If the reading from the test made at step c) is unstable when the katharometer block is tapped gently, this could indicate that a filament is damaged but not open circuit.

If any of these tests indicate that the katharometer is faulty the complete katharometer unit must be returned for repair or replacement.

The span adjustment of katharometer units are sealed and must not be adjusted unless necessary – see Section 8.4.2.

11.3 Routine Maintenance

11.3.1 Hydrogen Katharometer Calibration

Carry out a calibration check in accordance with Section 8.

This task should be carried out at intervals of 3 months of on-line use.

11.3.2 Purge Gas Katharometer Calibration

Carry out a calibration check in accordance with Section 8.3.

This task should be carried out before using the katharometer for monitoring a purging procedure.

11.3.3 Changing Desiccant in Drying Chamber

The need to change the desiccant in the drying chamber on the katharometer Analyzer panel depends on the condition of the sample gas.

It is recommended that the Analyzer system is monitored regularly during the initial phase of operation for indications that the desiccant is exhausted. Then a suitable maintenance interval for this task can be established.

As the desiccant degrades, the white grains can be seen to have a yellowish tinge and the granular form becomes more consolidated. If liquid contamination occurs, the desiccant becomes brown and consolidated.



Warning. Suitable safety precautions will apply to the operation of the gas cooling and sample systems.

- Isolate the sample gas system from the main system. Carry out a limited hydrogen purging operation on the sample system in accordance with the instructions of the responsible authority.
- Carry out the procedure given in Section 6.1.
- After purging any residual air from the sample system in accordance with the requirements of the responsible authority, allow hydrogen to pass through the katharometer again.

This task should be undertaken on the basis of instrument response or at intervals of 1 year.

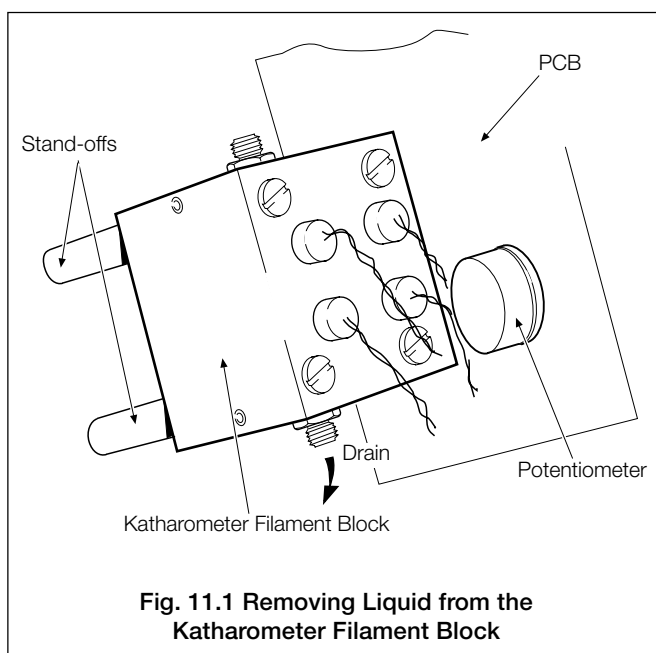

Fig. 11.1 Removing Liquid from the Katharometer Filament Block

11.4 Repair Maintenance

11.4.1 Removing Liquid from Katharometer Measurement Block – Fig. 11.1

If tests indicate that there is likely to be an accumulation of liquid in the katharometer filament block, it may be removed using the following procedure:

- Electrically isolate the defective katharometer at its PSU.
- Isolate the gas sample system to the particular katharometer from the main gas cooling system. Purge the sample system of hydrogen in accordance with the requirements of the responsible authority.



Warning. The thermal insulation inside the case must not be damaged or removed.

- Remove the cover of the katharometer unit and dismantle the internal sample system pipework.
- Remove the fixing screws which secure the mounting pillars to the case. See Fig. 5.2.
- Disconnect the interconnecting wiring at terminal block TB1.



Caution. Do not insert any type of probe into the gas system of the katharometer filament block assembly or use compressed air to blow through the system.

- Remove the katharometer filament block assembly from the case and tilt at 45° to the horizontal. This allows any liquid to drain from the measurement block. See Fig. 11.1.
- Pour a small quantity of rectified spirit (ethanol) through the katharometer filament block. Allow as much liquid as possible to drain out. Assist this by gentle shaking. Repeat this procedure several times until all evidence of contamination is removed.
- Fit the katharometer filament block assembly into its case. Replace the fixing screws and make the electrical interconnections at terminals TB1 – 1 and TB1 – 4.
- Fit the internal sample gas tubing.
- Remake the sample gas tube interconnection couplings.
- Replace the desiccant in the drying chamber in accordance with the procedure given in Section 11.3.3.
- Carry out a leak test in accordance with the requirements of the responsible authority.
- Power up the katharometer unit by switching on the appropriate PSU.
- Arrange to pass dry air or another suitable dry gas through the katharometer at the normal sample flowrate for 24 hours.
- Isolate the katharometer unit at its PSU.
- Make the remaining electrical connections at TB1 of the katharometer unit – see Fig. 5.3.
- Replace the cover of the katharometer unit.
- Power up the katharometer unit from its PSU.

...11 MAINTENANCE

- s) Carry out a calibration procedure in accordance with Section 8.3.



Note. It is possible that the zero reading may drift for several days after the removal of liquid.

This task should be undertaken as required.

11.4.2 Removal/Replacement of an Indicator Unit

- Electrically isolate the 6553 display unit.
- Release the retaining screw through the display facia and carefully withdraw the chassis from its edge connectors and out through the front panel. See Fig. 3.1.
- To replace the unit, carefully insert it into the display facia and press firmly into position before tightening the retaining screw.
- Power up the monitor unit and carry out a calibration in accordance with Section 8.3.

This task should be undertaken as required.

11.4.3 Error Messages

Table 11.1 shows error message(s) which may occur, explanation(s) and corrective action(s).

Error Message	Explanation
NV Memory Error	The contents of the non-volatile memory has not been read correctly during power up. *

* To rectify fault, switch OFF, wait 10 seconds and switch ON again. If fault persists, contact the Company.

Table 11.1 Error Messages

12 SPARE PARTS LIST



Warning. Interference with any unit or its components implies acceptance of responsibility by that person for ensuring the continuing maintenance of intrinsic safety requirements. Unauthorized repair, spare parts or incorrect assembly may render any unit unfit for use in an intrinsically safe application.



Note. Although the digital display units may be marked 4600 on their display facia, they are dedicated variants which are not interchangeable with the Company's standard 4600 Controller/Display. These dedicated display units are identified (4689 502) as shown in Fig. 3.1.

When ordering a katharometer unit, it is necessary to specify the zero gas and range in association with the Company part number. See the typical identification label shown in Fig. 3.2.

12.1 Consumables

Description	Part No.
Model 006548 000 & 006548 203	
Katharometer Analyzer Panels	
Granular anhydrous CaCl ₂	Locally sourced

12.2 Routine Maintenance Parts

Description	Part No.
Model 6553 Gas Monitor Unit	
Fuse, 500mA a/s 20 x 5 mm glass cartridge	0231 538
Function selector switch, 3 position, 2 wafer	0234 724
Potentiometer (1kΩ), zero adjustment	002569 036
Katharometer Analyzer Panel	006540 203 006548 000
Seal, top of drying chamber	002310 012 002310 012
Seal, bottom of drying chamber	006519 160 0211 035
Gauze, drying chamber	006525 700 006548 018

12.3 Repair Maintenance Parts

Description	Part No.
Model 4234 Power Supply Unit	
Nominal 230V unit	4234 500
Nominal 115V unit	4234 501
Fuses	
F2/F3 – 250mA/≥1500A HBC cartridge	0231577
F1 – 400mA cartridge	0231555
Katharometer Analyzer Panel	006540 203 006548 000
Flowmeter	006525 460 0216 485
Valve, metering	006525 480 0216 484
Coupling seal ring	006525 130
Katharometer unit (H₂)	006539 960K (or J) 006548 001
Katharometer unit (CO₂/Ar)	006539 960
Model 6553 Gas Monitor Unit	
Display units (H ₂ /CO ₂)	4689 502
Display units (H ₂ /Ar)	4689 505
Zener diode safety barrier devices	0248 297

(a) Model 6553 Gas Monitor Unit

13 SPECIFICATION

Model 6553 Gas Monitor

Approvals

CENELEC approved
[EEExia] IIC T_{amb} -20°C to +40°C
BASEEFA Certificate No. BAS 01 ATEX 7043

Available ranges

- (a) 100 to 85% H₂ in air + others (80% or 85% to 100%)
- (b) 0 to 100% H₂ in CO₂
- (c) 0 to 100% air in CO₂

Digital Display Units

Air in CO ₂ /H ₂ in CO ₂	Model 4689-500
100 to 85% H ₂ in air	Model 4689-501
All three ranges	Model 4689-502
85 to 100% H ₂ in Air	Model 4689-503
Air in N ₂ /H ₂ in N ₂	Model 4689-504
H ₂ in Air/Air in A/H ₂ in A	Model 4689-505

Range Selector Switch Positions (when fitted)

- (1) Percentage by volume, hydrogen in air
- (2) Percentage by volume, hydrogen in carbon dioxide
- (3) Percentage by volume, air in carbon dioxide

Accuracy (display units)

± 0.25% of scale span

Ambient Temperature Range

0 to 45°C (32 to 113°F)

Power Supply

110/120V ac or 200/220/240V a.c., 50/60Hz
(two separate versions)

Power Consumption

30VA approximately

Outline Dimensions

290 x 362 x 272mm (11.4 x 14.25 x 10.9 in.)

Weight

12kg (26.4lb)

Environment

Sheltered interior, 0 to 90% RH

Outputs and Set Points

No. of relays

Two

No. of set points

Two

Set point adjustment

Programmable

Set point hysteresis

±1% fixed

Local set point annunciation

Red l.e.d.

Relay contacts

Single pole changeover

Rating	250V a.c.	250V d.c. max.
	3A a.c.	3A d.c. max.
Loading (non-inductive)	750VA	30W max.
(inductive)	75VA	3W max.

Insulation

2kV r.m.s. contacts to earth (ground)

Retransmission

No. of retransmission signals

One fully isolated – standard

Output current

0 to 10mA, 0 to 20mA or 4 to 20mA programmable

Accuracy

±0.25% f.s.d. ±0.5% reading

Resolution

0.1% at 10mA, 0.05% at 20mA

Max. load resistance

750 ohm (20mA max.)

Series 4234 Power Supply Unit**Approvals**

CENELEC approved
 [EExia] IIC Tamb -20°C to 55°C
 BASEEFA Certificate No. BAS 01 ATEX 7041

Input Voltage

115V a.c. 50/60Hz or (Model 4234501)
 230V a.c. 50/60Hz (Model 4234500)

Fuse Rating

250mA HRC ceramic

DC Output

350mA stabilized $\pm 0.14\%$

Load Conditions

1 Katharometer 13 Ω max.
 Interconnecting cable 2 Ω max.

Ambient Temperature Range

-20 to 55°C (-4 to 131°F)

Supply Variations

$\pm 15V$ (115V supply) or $\pm 30V$ (230V supply) 46 to 64Hz

Regulation

Within $\pm 0.5\%$ for:

- (i) Load variation of $\pm 15\%$
- (ii) Supply variation of $\pm 15\%$
- (iii) Ambient temperature variation of $\pm 20^\circ\text{C}$ (36°F)
- (iv) $\pm 4\text{Hz}$ frequency variation

Ripple

Less than 0.5% of set output peak/peak across
 a 10 Ω load

Stability

Within $\pm 0.7\%$ of initial setting, over period of 1 month with load resistance, supply voltage and ambient temperature at nominal stated values

Outline Dimensions

117 x 170 x 110mm (4.6 x 6.7 x 4.3 in.)

Weight

2.12kg (4.8 lb) approx.

Environment

Sheltered interior

**Models 6540–203 and 6548–000
Katharometer Analyzer Panel****Approvals**

CENELEC approved EExia IIC T4. T_{amb}
 -20°C to +55°C

BASEEFA Certificate No. BAS 01 ATEX 1042

Model 6540–203 incorporating Model 6539–960 (H₂) or
 Model 6539–960 (CO₂) Katharometer Unit

Model 6548–000 incorporating Model 6548–001
 (H₂ and CO₂) Katharometer Unit

Power Supply

350mA d.c., from Model 4234500 or 4234501 Power Supply Unit

Signal Output

0 to 10mV for each range

Accuracy

$\pm 2\%$ of scale span, each range

Dead Time

Typically 5s

Response Time

Typically 40s for 90% step change at Katharometer
 Tubing and drying chamber introduce extra delays

Ambient Temperature

55°C (131°F) max.

Sample Connections

Compression couplings:
 6mm o.d. tube (Model 6548-000)
 8mm o.d. tube (Model 6540-203)

Sample Pressure

Minimum 125mm H₂O
 Maximum 0.35 bar (Gauge) Model 6540–203
 Maximum 10 bar (Gauge) Model 6548–000

Normal Sample Flowrate

100 to 150ml/min.

Maximum Gas Flowrate

250ml/min

Minimum Gas Flowrate

50ml/min

Outline Dimensions

610 x 305 x 152mm (24 x 12 x 6 in.)

Weight

8.6kg (18.9lb)

Environment

Sheltered interior

Notes.

1. Systems can be supplied for use with Nitrogen or Argon purge gases as an alternative to the CO₂ ranges. Details on application to the Company.

2. Variations to the earlier certificate (SFA 3012:1972) allow the use of these items in systems supplied previously to that standard.

NOTES

PRODUCTS & CUSTOMER SUPPORT

Products

Automation Systems

- *for the following industries:*
 - Chemical & Pharmaceutical
 - Food & Beverage
 - Manufacturing
 - Metals and Minerals
 - Oil, Gas & Petrochemical
 - Pulp and Paper

Drives and Motors

- *AC and DC Drives, AC and DC Machines, AC motors to 1kV*
- *Drive systems*
- *Force Measurement*
- *Servo Drives*

Controllers & Recorders

- *Single and Multi-loop Controllers*
- *Circular Chart, Strip Chart and Paperless Recorders*
- *Paperless Recorders*
- *Process Indicators*

Flexible Automation

- *Industrial Robots and Robot Systems*

Flow Measurement

- *Electromagnetic Flowmeters*
- *Mass Flow Meters*
- *Turbine Flowmeters*
- *Flow Elements*

Marine Systems & Turbochargers

- *Electrical Systems*
- *Marine Equipment*
- *Offshore Retrofit and Refurbishment*

Process Analytics

- *Process Gas Analysis*
- *Systems Integration*

Transmitters

- *Pressure*
- *Temperature*
- *Level*
- *Interface Modules*

Valves, Actuators and Positioners

- *Control Valves*
- *Actuators*
- *Positioners*

Water, Gas & Industrial Analytics Instrumentation

- *pH, conductivity, and dissolved oxygen transmitters and sensors*
- *ammonia, nitrate, phosphate, silica, sodium, chloride, fluoride, dissolved oxygen and hydrazine analyzers.*
- *Zirconia oxygen analyzers, katharometers, hydrogen purity and purge-gas monitors, thermal conductivity.*

Customer Support

We provide a comprehensive after sales service via a Worldwide Service Organization. Contact one of the following offices for details on your nearest Service and Repair Centre.

United Kingdom

ABB Limited
Tel: +44 (0)1453 826661
Fax: +44 (0)1453 829671

United States of America

ABB Inc.
Tel: +1 (0) 755 883 4366
Fax: +1 (0) 755 883 4373

Client Warranty

Prior to installation, the equipment referred to in this manual must be stored in a clean, dry environment, in accordance with the Company's published specification.

Periodic checks must be made on the equipment's condition. In the event of a failure under warranty, the following documentation must be provided as substantiation:

1. A listing evidencing process operation and alarm logs at time of failure.
2. Copies of all storage, installation, operating and maintenance records relating to the alleged faulty unit.

ABB has Sales & Customer Support
expertise in over 100 countries worldwide

www.abb.com

The Company's policy is one of continuous product
improvement and the right is reserved to modify the
information contained herein without notice.

Printed in UK (04.04)

© ABB 2004



ABB Limited
Oldends Lane, Stonehouse
Gloucestershire, GL10 3TA
UK
Tel: +44 (0)1453 826661
Fax: +44 (0)1453 829671

ABB Inc.
2175 Lockheed Way
Carson City, NV 89706
USA
Tel: +1 (0) 775 883 4366
Fax: +1 (0) 775 883 4373